

Agilent Designing and Testing 3GPP W-CDMA User Equipment

Application Note 1356

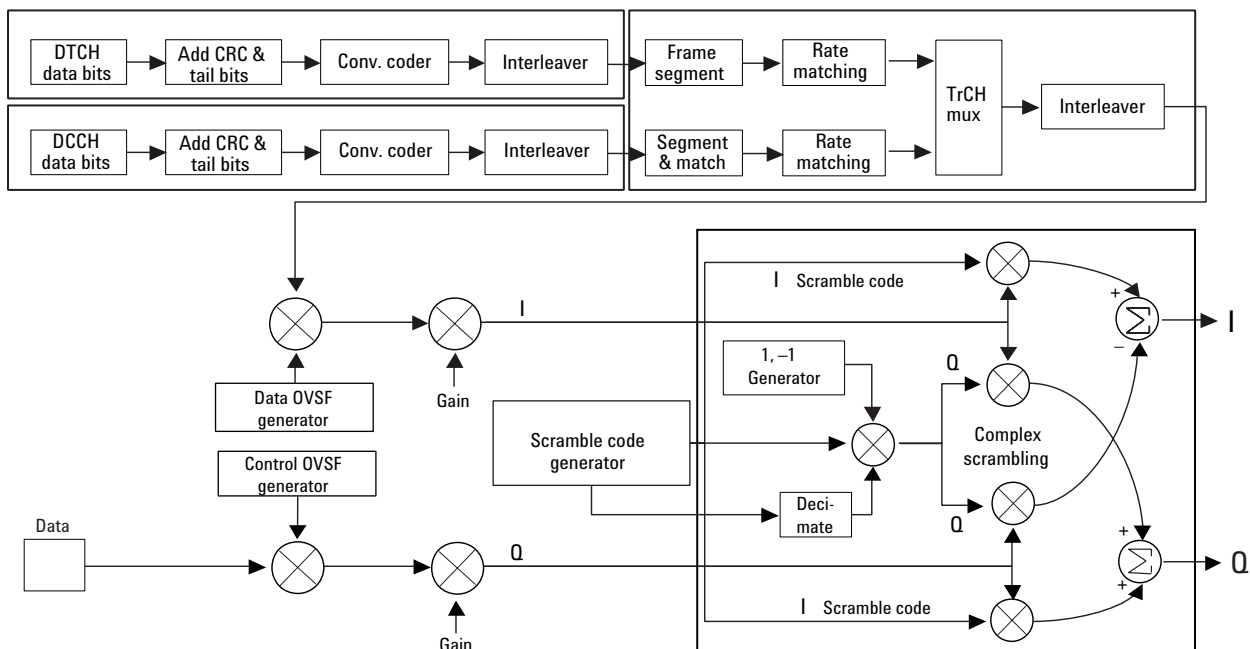

Table of contents

Introduction	3
1 Basic concepts of W-CDMA	4
1.1 Code division multiple access	4
1.2 Base transceiver station and user equipment identification	5
1.3 Data channelization	5
1.4 Slots, frames, and power control	7
1.5 Protocol structure	7
1.6 Logic, transport, and physical channels	8
1.7 Downlink physical channels	9
1.8 Uplink physical channels	11
1.9 Downlink DPDCH/DPCCH coding and air interface	11
1.10 Uplink DPDCH/DPCCH coding and air interface	12
1.11 Reference measurement channels	14
1.12 Asynchronous cell site acquisition	14
1.13 Asynchronous cell site soft handover	15
2 General design and measurement issues	16
2.1 Controlling interference	16
2.1.1 Average RF power	16
2.1.2 Adjacent channel interference	18
2.2 Maximizing battery life	19
2.2.1 Complementary cumulative distribution function (CCDF)	20
2.3 Measuring modulation quality	22
2.3.1 QPSK EVM	23
2.3.2 Composite EVM	24
2.3.3 Code domain power	28
2.3.4 Peak code domain error	31
2.3.5 Symbol EVM	32
2.3.6 Symbol power versus time	33
2.3.7 Demodulated bits	34
2.4 Measuring receiver functionality and performance	35
2.4.1 Timeslot synchronization testing and searcher testing	36
2.4.2 Verification of demodulation and despreading	37
2.4.3 Verification of TFCI decoding and power offset effects	38
2.4.4 Verification of response to TPC commands	38
2.4.5 Analysis of receiver's response to channel configuration changes	39
2.4.6 Bit error rate (BER) versus block error rate (BLER)	39
Summary	41
Appendix A: Reference measurement channel examples	42
Appendix B: Agilent solutions for W-CDMA UE design and test	44
Acronym glossary	49
References	50
Related literature	51
Acknowledgements	51

Introduction

W-CDMA is one of the leading wideband digital cellular technologies that will be used for the third generation (3G) cellular market.

The earlier Japanese W-CDMA trial system and the European Universal Mobile Telephone System (UMTS) have both served as a foundation for the workings of this harmonized W-CDMA system, under the supervision of the Third-Generation Partnership Project (3GPP). The 3GPP organizational partners are the European Telecommunications Standard Institute (ETSI), the Japanese Association of Radio Industries and Businesses (ARIB), the Japanese Telecommunication Technology Committee (TTC), the Korean Telecommunications Technology Association (TTA), and the American Standards Committee T1 Telecommunications. The harmonized system is sometimes referred to as 3GPP W-CDMA, to distinguish it from earlier wideband CDMA versions.

The W-CDMA system will employ wideband CDMA in both frequency division duplex (FDD) and time division duplex (TDD) modes. To limit its scope, this application note focuses on the FDD mode of W-CDMA, although most of the content is applicable to both modes. Whenever the term W-CDMA is used throughout the application note it is in reference to the 3GPP (release 99) specifications for W-CDMA FDD mode.

This application note focuses on the physical layer (layer 1) aspects of W-CDMA user equipment (UE)¹. It consists of

- A brief overview of W-CDMA technology
- A discussion of design issues and measurement concepts related to the technology that are important for the W-CDMA UE air interface because of the differences between W-CDMA and its second generation (2G) predecessors (specifically, Global System for Mobile Communication (GSM) and Personal Digital Cellular (PDC)). This section will provide you with an understanding of why these measurements are important and how you can use them to characterize and troubleshoot your design. These measurements can be useful throughout the development of the UE. This section can also be used as background information for conformance and manufacturing testing.
- A list of Agilent Technologies' solutions for the physical layer of W-CDMA UE design and test

You can find further information about 3G technologies at the following URL: <http://www.agilent.com/find/3G>

1. The W-CDMA specifications use the term UE to refer to mobile phones, wireless computing devices, or other devices that provide wireless access to the W-CDMA system.

1 Basic concepts of W-CDMA

W-CDMA is designed to allow many users to efficiently share the same RF carrier by dynamically reassigning data rates and link budget to precisely match the demand of each user in the system. Unlike some 2G and 3G CDMA systems, W-CDMA does not require an external time synchronization source such as the global positioning system (GPS) [1].

1.1 Code division multiple access

As its name implies, W-CDMA is a code division multiple access (CDMA) system. As opposed to time division multiple access (TDMA), in CDMA, all users transmit at the same time. Frequency divisions are still used, but at a much larger bandwidth. In addition, multiple users share the same frequency carrier. Each user's signal uses a unique code that appears to be noise to all except the correct receiver. Therefore, the term *channel* describes a combination of carrier frequency and code. Correlation techniques allow a receiver to decode one signal among many that are transmitted on the same carrier at the same time. Figure 1 shows a simplified version of the transmission and reception processes for a CDMA system. Although this example uses W-CDMA data rate and bandwidth parameters, the basic processes are the same for all CDMA systems. One difference between W-CDMA and the existing 2G CDMA system (IS-95) is that W-CDMA uses a wider bandwidth (3.84 MHz, as opposed to 1.23 MHz for IS-95).

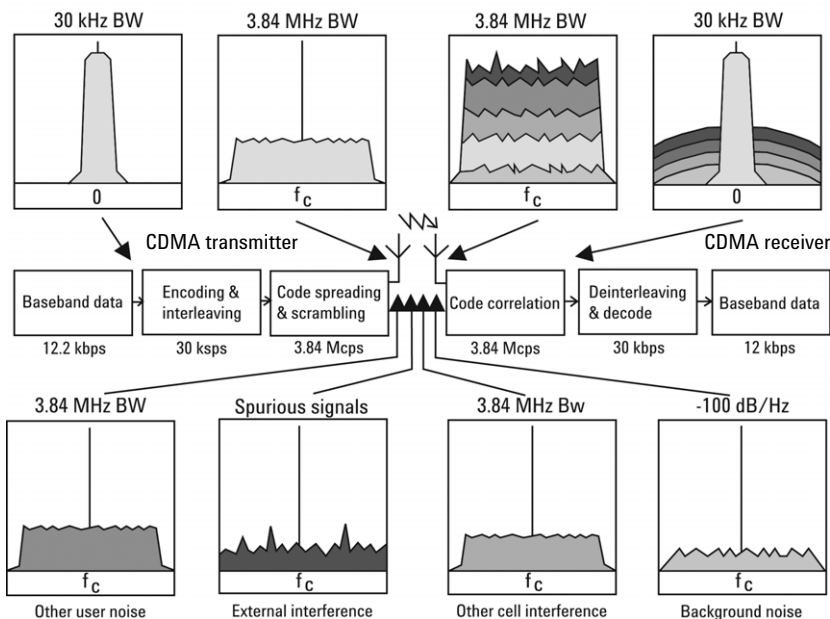

Figure 1. CDMA transmission and reception processes

In the above example, the W-CDMA system starts with a narrowband signal at a data rate of 12.2 kbps. In reality, this data rate is variable, up to 2 Mbps. After coding and interleaving, the resulting symbol rate in this example is 30 ksps. This is spread with the use of specialized codes to a bandwidth of 3.84 MHz. The final spread bits are called chips, and the final spread rate is defined in terms of chips per second (3.84 Mcps for W-CDMA). The ratio of the spread data rate (3.84 Mcps) to the encoded data rate (30 ksps in this case) is called the spreading gain. The ratio of the spread data rate to the initial data rate (12.2 kbps in this case) is called the processing gain (overall coding gain). In CDMA systems the spreading gain is a big contributor to the processing gain. The processing gain allows the receiver's correlator to extract the desired signal from the noise. When transmitted, a CDMA signal experiences high levels of

interference, dominated by the signals of other CDMA users. This takes two forms, interference from other users in the same cell and interference from adjacent cells. The total interference also includes background noise and other spurious signals. When the signal is received, the correlator recovers the desired signal and rejects the interference. This is possible because the interference sources are uncorrelated to each channel's unique code. In W-CDMA, the unique code for each channel is a combination of the scrambling code and the orthogonal variable spreading factor (OVSF) code, which are described in the following sections.

1.2 Base transceiver station and user equipment identification

As in other CDMA systems, in W-CDMA each base transceiver station (BTS) output signal is "scrambled" by multiplying all of its data channels by a unique pseudo-noise (PN) code, referred to in the W-CDMA specification as a scrambling code. The UE receiver can distinguish one BTS from another by correlating the received signal spectrum with a scrambling code that is identical to that used in the desired BTS. Similarly, each UE output signal is scrambled with a unique scrambling code that allows the BTS receiver to discern one UE from another. The scrambling codes are applied at a fixed rate of 3.840 Mcps. The scrambling codes are not orthogonal, therefore, some interference can exist between two UEs.

1.3 Data channelization

Beside distinguishing which transmitter is being listened to, a CDMA receiver must further distinguish between the various channels originating from that transmitter. For example, a BTS will transmit unique channels to many mobile users, and each UE receiver must distinguish each of its own channels from all the other channels transmitted by the BTS. In W-CDMA, this function is provided by the channelization codes, also known as OVSF codes.

OVSF codes are orthogonal codes similar to the Walsh codes used in IS-95 and cdma2000. Each channel originating from a W-CDMA BTS or UE is multiplied by a different OVSF code¹. In IS-95, Walsh codes are fixed at 64 chips in length; in W-CDMA, the length of these codes, also known as the spreading factor (SF), can be configured from 4 to 512 chips, with the resulting downlink (DL) symbol rate being equal to the system chip rate of 3.84 Mcps divided by the SF. For example, a SF of four corresponds to a symbol rate of 960 ksps.

The entire set of OVSF codes is identical for each UE and BTS. The scrambling code allows OVSF code reuse among UE and BTS within the same geographic location. Therefore, it is the combination of OVSF and scrambling codes that provides a unique communication channel between a UE and BTS.

1. The synchronization channels are an exception to this, as described later.

The W-CDMA radio link between the BTS and UE must support multiple simultaneous data channels. For example, a 3G connection may include bi-directional voice, video, packet data, and background signaling messages, each representing a unique data channel within a single frequency carrier.

Figure 2 illustrates a W-CDMA system with two BTS and four UEs. The scrambling code (SC) provides a unique identity to each UE and each BTS. The OVSF code allocations provide a unique identity to each channel conveyed by a UE or BTS within one cell. For example SC₂ identifies BTS 2, and SC₆ identifies UE 4. BTS 2 uses OVSF₄ and OVSF₅ to send voice and signaling information to UE 4. This UE uses OVSF₁ and OVSF₂ to send voice and signaling information back to BTS 2. Note that other BTSs and UEs also use the same OVSF codes (OVSF₁ and OVSF₂). This is not a problem since the scrambling codes decorrelate the re-used OVSF codes.

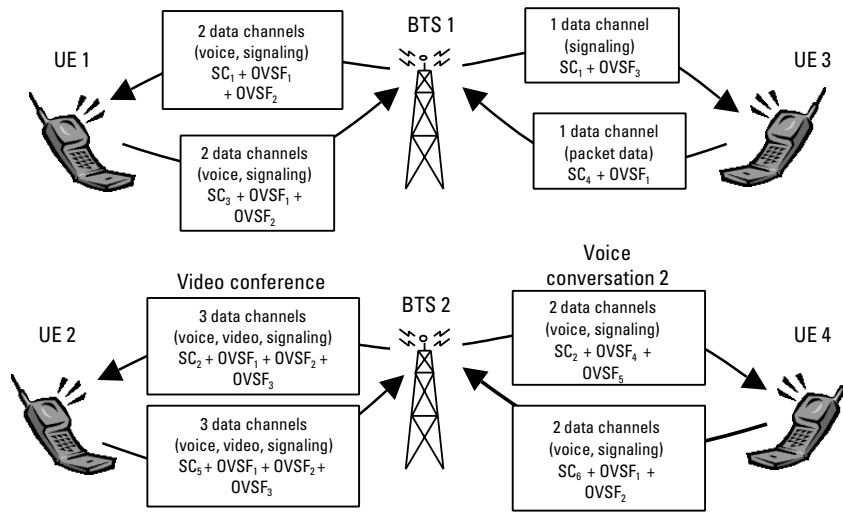

Figure 2. W-CDMA code allocations

The combination of OVSF codes and scrambling codes provide the signal spreading, and therefore, the spreading gain needed for the receiver correlators to pull the desired signal out of the noise. The SF determines the degree of spreading gain. For high data rate signals, the SF and spreading gain are lower. For the same level of interference, the amplitude for high data rate channels must be higher, in order for all channels to maintain equal energy-per-bit-to-noise ratio (E_b/N_0).

SFs may be reassigned as often as every 10 ms. This allows the W-CDMA network to dynamically reassign bandwidth that would otherwise be wasted. In effect, the total data capacity within W-CDMA can be allocated in a more efficient manner as compared with 2G CDMA systems (IS-95) that use fixed-length orthogonal codes.

1.4 Slots, frames, and power control

All W-CDMA uplink (UL) and DL data channels are segmented into time slots and frames. A slot is 666.667 μ sec in length, equal in duration to 2560 chips of the system chip rate. Fifteen of these time slots are concatenated to form a 10 ms frame (figure 3). The frame is the fundamental unit of time associated with channel coding and interleaving processes. However, certain time-critical information, such as power control bits, are transmitted in every time slot. This facilitates UE power control updates at a rate of 1500 adjustments per second to optimize cell capacity.

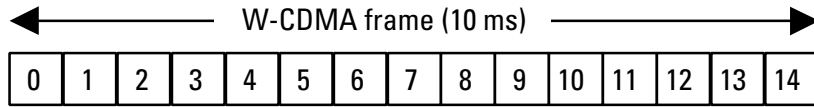

Figure 3. W-CDMA slot and frame structure

In any cellular CDMA system, the BTS must precisely control the transmit power of the UEs at a rate sufficient to optimize the link budget. This is referred to as UL power control. The goal is to balance the power received at the BTS from all UEs within a few dB, which is essential to optimizing the UL spread spectrum link budget. Unlike IS-95, the UE sends power control bits to the BTS at the same rate, and the BTS responds by adjusting the power of the data channels that are intended for the respective UE. This is referred to as DL power control.

1.5 Protocol structure

The protocol structure of the W-CDMA system closely follows the industry standard open system interconnection (OSI) model. Figure 4 shows the three bottom layers.

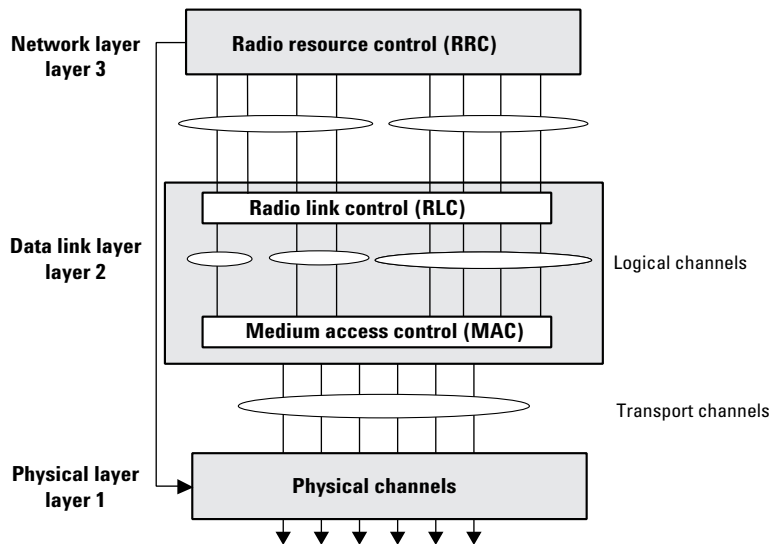

Figure 4. W-CDMA protocol structure

The network layer (layer 3) is based heavily on GSM standards. It is responsible for connecting services from the network to UE. The data link layer (layer 2) is composed of two main functional blocks: the radio link control (RLC) and medium access control (MAC) blocks [3]. The RLC block is responsible for the transfer of user data, error correction, flow control, protocol error detection and recovery, and ciphering. The MAC function at layer 2 is responsible for mapping between logical channels and transport channels (see following section). This includes providing for the multi-

plexing/de-multiplexing of various logical channels onto the same transport channel. The physical layer (layer 1) maps the transport channels onto the physical channels and performs all of the RF functions necessary to make the system work. These functions include operations such as frequency and time synchronization, rate matching, spreading and modulation, power control, and soft handoff. This application note focuses on layer 1 and refers to layer 2 briefly when appropriate. For more information on layer 2 refer to [3] and [4]. See [5] for information on layer 3. See [6] for more information on the protocol architecture.

1.6 Logical, transport, and physical channels

Logical channels are the information content, which will ultimately be transmitted over the physical channels. Logical channels include the Broadcast Control Channel (BCCH), the Paging Control Channel (PCCH), the Common Control Channel (CCCH), and Dedicated Control and Traffic Channels (DCCH, DTCH).

W-CDMA introduces the concept of transport channels to support sharing physical resources between multiple services. Each service, such as data, fax, voice, or signaling, is routed into different transport channels by the upper signaling layers. These services may have different data rates and error control mechanisms. The transport channels are then multiplexed as required prior to transmission via one or more physical channels. High data rate services or a combination of lower rate transport channels may be multiplexed into several physical channels. This flexibility allows numerous transport channels (services) of varying data rates to be efficiently allocated to physical channels. By multiplexing these transport channels efficiently, system capacity is optimized. For example, if the aggregate data rate of three transport channels exceeds the maximum of a single physical channel, then the data can be routed to two lower rate physical channels that closely match the total required data rate. Transport channels include the Broadcast Channel (BCH), the Paging Channel (PCH), the Forward Access Channel (FACH), the Dedicated Channel (DCH) and the Random Access Channel (RACH). [7]

The W-CDMA DL is composed of a number of physical channels. The most important DL physical channels are the Common Pilot Channel (CPICH), the Primary Common Control Physical Channel (P-CCPCH), the Secondary Common Control Physical Channel (S-CCPCH), and the Dedicated Physical Data and Control Channels (DPDCH/DPCCH). The UL consists of a Physical Random Access Channel (PRACH), a Physical Common Packet Channel (PCPCH), and Dedicated Physical Data and Control Channels (DPDCH/DPCCH). These channels are described in the following sections.

Figure 5 shows an example of channel mapping for the DL. When a UE is in the idle mode, the BTS sends dedicated signaling information from the DCCH logical channel through the FACH transport channel. This maps the information onto the S-CCPCH physical channel for transmission to a UE. When the UE is in the dedicated connection mode, the same signaling information is routed through the DCH transport channel. This maps the information onto the DPDCH/DPCCH physical channel for transmission to the UE.

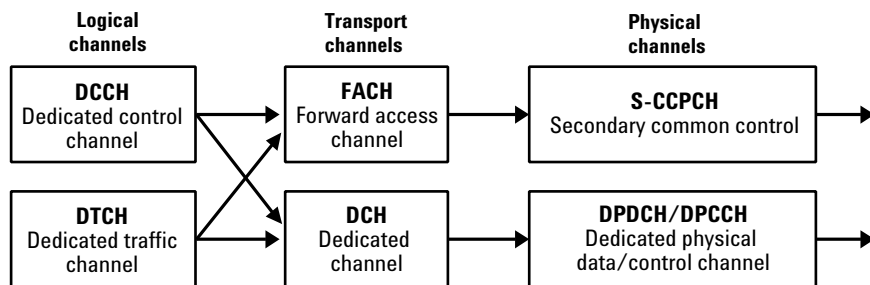

Figure 5. Example of logical, transport, and physical channel mapping (DL)

1.7 Downlink physical channels

Figure 6 shows the slot and frame structure for the CPICH, P-CCPCH and SCH.

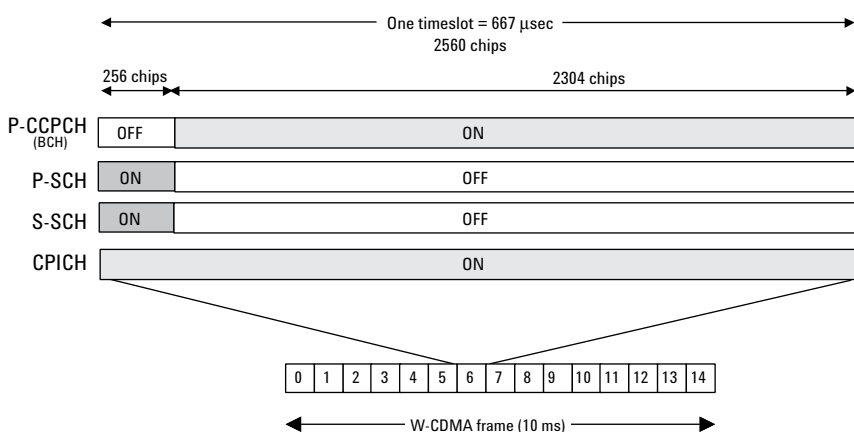

Figure 6. CPICH, P-CCPCH and SCH slot and frame structure

The CPICH is a continuous loop broadcast of the BTS scrambling code. As described earlier, the scrambling code provides identification of the BTS transmission. The UE uses the CPICH as a coherent reference for precise measurement of the BTS time reference, as well as to determine the signal strength of surrounding BTS before and during cell site handover. Since no additional spreading is applied to this signal, it is quite easy for the UE to acquire a lock to this reference. This must occur before any other channels can be received.

The P-CCPCH is time multiplexed with an important channel used by the UE during system acquisition, the Synchronization Channel (SCH). This carries two sub-channels, the Primary Synchronization Channel (P-SCH) and Secondary Synchronization Channel (S-SCH). These channels consist of two codes known as Primary Synchronization Code (PSC) and Secondary Synchronization Code (SSC). The PSC is a fixed 256-chip code broadcast by all W-CDMA BTS. During initial acquisition, the UE uses the PSC to determine if a W-CDMA BTS is present and establish the slot boundary timing of the BS. The SSC represents a group, called a code group, of 16 sub-codes, each with a length of 256 chips. The BTS transmits these codes in an established order, one SSC sub-code in each time slot of a frame. When a UE decodes 15 consecutive SSC transmissions, it can determine the BTS frame boundary timing, as well as derive information that will aid in the identification of the BTS scrambling code (see chapter 2). The SCH is transmitted during the first 256 chips of each time slot while the P-CCPCH is off (figure 6). During the remaining 2304 chips of each slot the P-CCPCH is transmitted, which contains 18 bits of broadcast data (Broadcast

Transport Channel (BCH) information) at a rate of 15 kbps. Since the cell's broadcast parameters message will require more than 18 bits, the broadcast information may span several frames.

The Dedicated Physical Channel (DPCH) carries all the user data and user signaling, as well as physical channel control bits for the slot format and the UE inner loop power control. The DPCH consists of the DPDCH and the DPCCH (figure 7). The user's digitized voice and/or digital data, along with layer 3 signaling data, are carried on the DPDCH. The user data and signaling data are individually treated with error protection coding and interleaving, then multiplexed together to form the DPDCH. The DPDCH is then multiplexed with the DPCCH, which contains the Transmit Power Control (TPC) bits (to control the UE transmit power), Transport Format Combination Indicator (TFCI) bits (indicates the slot format and data rate), and embedded Pilot bits (short synchronization patterns embedded within each slot).

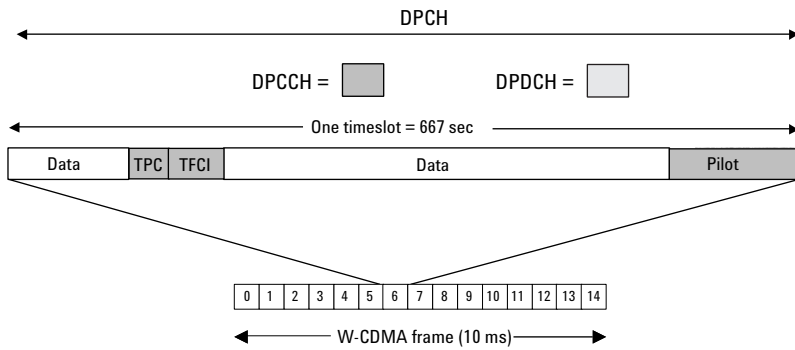

Figure 7. DPCH (DPDCH/DPCCH) slot and frame structure

Other DL channels include the Secondary Common Control Physical Channel (S-CCPCH), used to transmit pages and signaling to idling UEs; the Acquisition Indication Channel (AICH), used to acknowledge UE access requests; a Paging Indication Channel (PICH), used to alert the UE of a forthcoming page message; a Physical Downlink Shared Channel (PDSCH), used to dish out packet data to a number of UEs; and additional DPDCHs to increase DL data throughput for a single UE.

1.8 Uplink physical channels

The PRACH carries the RACH transport channel used by the UE to request registration on the network. RACH transmissions begin with a short preamble pattern that alerts the BS of the forthcoming RACH access message. The RACH message, which includes the identification of the UE, is spread using a cell-specific scrambling code so that only the targeted BTS will recognize the access attempt. In general, the RACH transmission can be initiated at any random instant and is therefore subject to collisions with other users. In this case, the UE will retransmit the message using different time slots until an acknowledgment is received.

The PCPCH carries the CPCH transport channel and it is used for UL packet data transmission. The CPCH is an efficient way to send UL packet data since it requires fewer system resources as compared with a dedicated data channel. It is a random access channel and uses access procedures similar to the RACH. Since a packet transmission may span several frames, it is necessary for the BTS to control the PCPCH transmit power. After the CPCH access attempt is successfully acknowledged, the UE begins transmitting and the BTS responds with power control bits. Once the transmit power is stabilized, the UE will commence transmission of a multi-frame packet.

The UL DPDCH/DPCCH carries the user's digitized voice and data channels along with layer 3 signaling data. The payload data and signaling data (DPDCH) are transmitted on the "I" path of the QPSK modulator; the power control, pilot, and other overhead bits (DPCCH) are transmitted on the "Q" path. Multiple DPDCHs may be transmitted. In this case they are consecutively assigned to either the I or Q paths. Each channel is spread by an OVSF code and its amplitude can be individually adjusted. Before modulation, the composite spread signal is scrambled with a special function that minimizes the signal transitions across the origin of the IQ plane and the 0° phase shift transitions. This improves the peak-to-average power ratio of the signal [8].

1.9 Downlink DPDCH/DPCCH coding and air interface

Figure 8 shows an example of the coding, spreading, and scrambling for the DPCH. In this example, a 12.2 kbps voice service is carried on a DTCH logical channel that uses 20 ms frames. After channel coding, the DTCH is coded with a 1/3 rate convolutional encoder. In this example, the data is then punctured (rate matching) and interleaved. At this point, the DTCH is segmented into 10-ms frames to match the physical channel frame rate. The DCCH logical channel carries a 2.5 kbps data stream on a 40 ms frame structure. The DCCH is coded in the same manner as the DTCH. Frame segmentation for the DCCH involves splitting the data into four 10-ms segments to match the physical channel frame rate. The DTCH and DCCH are multiplexed together to form the Coded Composite Transport Channel (CCTrCH). The CCTrCH is interleaved and mapped onto a DPDCH running at 42 kbps.

In this example, the DPCCCH is running at a rate of 18 kbps. The DPDCH and DPCCCH are time multiplexed together (DPCH) to form a 60 kbps stream. This stream is converted into separate I and Q channels with a symbol rate of 30 kbps for each channel. The DPCH is spread with an OVSF code with spread factor equal to 128 (to reach the desired 3.84 Mcps), which differentiates the signal from others within the cell or sector. After that process, it is complex scrambled with a code that identifies each cell or sector. The resulting I and Q signals are then filtered and used to modulate the RF carrier (not shown in the figure).

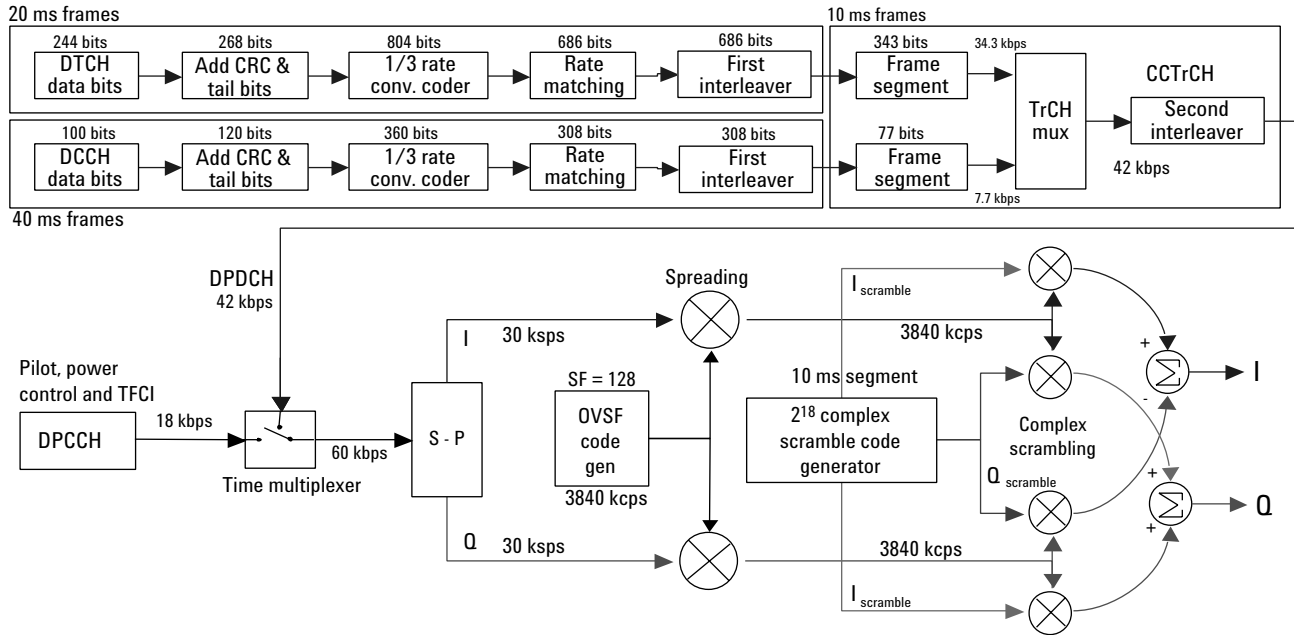

Figure 8. Downlink DPDCH/DPCCH coding, spreading, and scrambling. (For an alternative description, refer to [2], [9], and [10].)

1.10 Uplink DPDCH/DPCCH coding and air interface

The spreading and scrambling used on the UL DPDCH/DPCCH differ from the DL in two key areas: I/Q multiplexing and hybrid phase shift keying (HPSK) scrambling (instead of complex scrambling). Figure 9 shows an example of the coding and air interface for an UL DPDCH and DPCCH. In this example, the logical DTCH carries a 12.2 kbps voice channel and the logical DCCH carries a 2.5 kbps signaling channel. Each of these logical channels is channel coded, convolutionally coded, and interleaved. The DTCH uses 20-ms frames. At the frame segmentation point, the DTCH is split into two parts to conform with the physical layer's 10-ms frame structure. The DCCH, which operates with 40-ms frames, is split into four parts so that each signaling frame is spread over four 10-ms radio frames. These channels are then punctured (rate matching) and multiplexed prior to spreading. The multiplexed data at this point is called the Coded Composite Transport Channel (CCHTrCH). After a second interleaving, the CCHTrCH is mapped onto a DPDCH running at 60 kbps. The DPDCH is spread with an OVSF code with spread factor equal to 64 in order to reach the desired 3.84 Mcps. After gain scaling (to adjust the transmission power for the variable spreading factor), the spread DPDCH is applied to the I channel.

The data rate for the UL DPCCH is always 15 kbps. The DPCCH data is spread with an OVSF code with SF = 256 to reach the 3.84 Mcps rate and is gain scaled in this example to be -6 dB relative to the DPDCH. The DPCCH is then applied to the Q channel. If additional DPDCHs were present they would be assigned to I or Q and spread with the appropriate OVSF code. Before modulation, the composite spread signal is scrambled with a special complex function that limits the signal transitions across the origin of the IQ plane and the 0° phase shift transitions. This improves its peak-to-average power ratio. This function can be considered a variation of regular complex scrambling and is commonly known as HPSK, although this term is not mentioned in the 3GPP specifications. The scrambling generator produces two random sequences (referenced in the 3GPP specifications as $C_{long,1}$ and $C_{long,2}$, if long scrambling sequences are used [9]). The second sequence is decimated, multiplied by the function {1,-1} and by the first sequence, and applied to the Q path of the complex scrambler. The first sequence is applied to the I path of the complex scrambler. For a more detailed description of HPSK please refer to [8].

The resulting I and Q signals are then filtered and used to modulate the RF carrier (not shown in the figure).

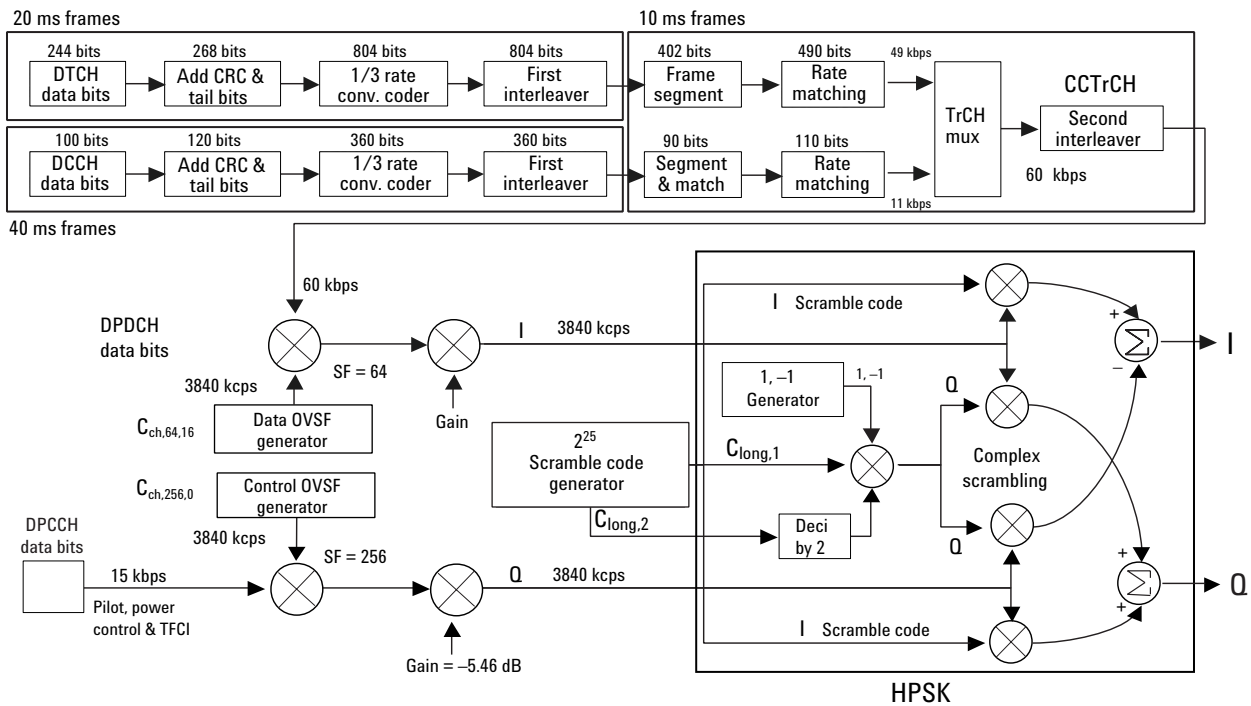

Figure 9. Uplink DPCH/DPCCH coding, spreading, and scrambling. (For an alternative description, refer to [2], [9], and [10].)

1.11 Reference measurement channels

In order to avoid ambiguity and inconsistency across different equipment suppliers, the 3GPP specifications define the UL and DL channel configurations to use for UE transmitter and receiver conformance testing, respectively [12]. These configurations are called reference measurement channels. There are four DL reference measurement channels and five UL reference measurement channels. All of them consist of a DPDCH and a DPCCH. The main difference between the four DL or five UL reference measurement channels is the information bit rate for the DTCH logical channel (12.2 kbps, 64 kbps, 144 kbps, and 384 kbps). A 768 kbps information bit rate is also available for the UL only.

The data rates in the channel configuration example in figure 8 correspond to the 12.2 kbps DL reference measurement channel. The data rates in the channel configuration example in figure 9 correspond to the 12.2 kbps UL reference measurement channel. The 12.2 kbps UL (or DL) reference measurement channel is the test channel configuration specified for most UE transmitter (or receiver) conformance tests. Appendix A provides the complete structure and parameter description for the 12.2 kbps UL and DL reference measurement channels as they appear in the 3GPP specifications [12].

1.12 Asynchronous cell site acquisition

Other CDMA systems use GPS to precisely synchronize the time reference of every BTS. This provides the benefit of simplifying acquisition and inter-cell handover. In particular, the scrambling codes, short PN codes, used by IS-95 BTS are uniquely time-delayed versions of the same code. A time-delayed version of a PN code behaves as if it were a statistically independent code, so each BTS can therefore be distinguished based on a simple time offset measurement rather than a complicated search through multiple codes. Furthermore, soft handover is simplified since the frame timing of every BTS is closely synchronized. This technique, while simplifying UE operation, requires GPS synchronization and code offset planning at the cell sites in order to insure that no PN code can be confused with another after undergoing propagation delay.

One of the W-CDMA design goals was to remove the requirement for GPS synchronization. Without dependence on GPS, the system could potentially be deployed in locations where GPS is not readily available, such as in a basement of a building or in temporary locations. W-CDMA accomplishes this asynchronous cell site operation through the use of several techniques.

First, the scrambling codes in W-CDMA are Gold codes rather than PN codes. In W-CDMA, the Gold codes are unique codes rather than time offsets of the same code. Therefore, precise cell site time synchronization is not required. There are, however, 512 unique Gold codes allocated for cell site separation. The UE must now search through a number of scrambling codes, rather than simply searching through various time offsets of the same code. In order to facilitate this task, the SSC in the S-SCH channel is used to instruct the UE to search through a given set of 64 Gold codes. Each set represents a group of eight scrambling codes ($64 \times 8 = 512$). The UE then tries each of the eight codes within each code group, in an attempt to decode the BCH. The ability to recover the BCH information (system frame number) completes the synchronization process.

1.13 Asynchronous cell site soft handover

In CDMA soft handover, a UE can establish simultaneous communication with several BS. During soft handover the combined signals from each BTS are individually correlated and then combined. As such, communication is possible in situations where an individual signal from a single BTS might otherwise be too weak to support the radio link.

With each W-CDMA BTS operating on an asynchronous clock, soft handover is complicated by the fact that frame timing between BTS is not explicitly coordinated. The UE could therefore have a difficult time combining frames from different BTS. To get around this problem, the W-CDMA UE measures the frame timing differential between the originating BTS and the handover target BTS. The UE reports this frame timing back to the network, which then issues a frame timing adjustment command to the target BTS. The target BTS adjusts the frame timing of the DPDCH/DPCCH channel that is being transmitted so the UE receives the target BTS frames in close time alignment with the corresponding frames from the originating BTS. With this time alignment feature, the UE's rake receiver is able to track the received signals from both BTS.

2 General design and measurement issues

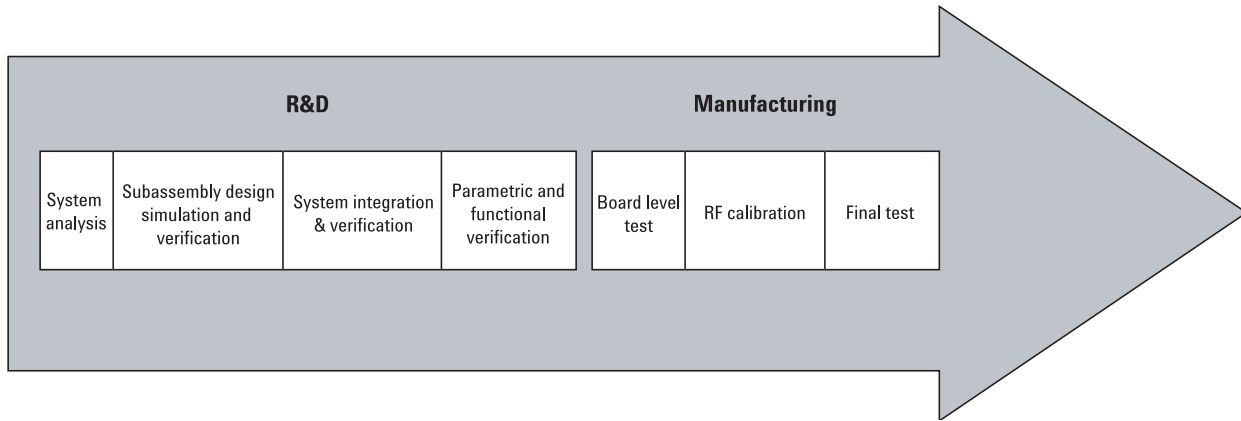

Figure 10. Generic diagram for the R&D and manufacturing phases of a UE

Figure 10 shows a generic diagram for the R&D and manufacturing phases of a UE. This chapter focuses on the development phase of the UE, highlighted in white. However, it does contain general information that may be useful to engineers involved in any area of the UE life cycle.

2.1 Controlling interference

In CDMA systems, each active user communicates at the same time, on the same frequency. Because each user uses a different spreading code, they look like random interference to each other. The capacity of the system is ultimately determined by the minimum operating signal to interference ratio (SIR) of the receiver. But, whatever the budget is, the number of users that can coexist in one frequency channel depends on the level of interference generated by each user. This is a statistical quantity that depends on many factors, ranging from network topology down to how a user holds his or her phone. As a result, system design has proven to be heavily dependent on detailed simulations.

Two important performance factors that can be specified, measured, and controlled are adjacent channel interference and average power. Power leakage from adjacent channels contributes to the noise floor of the channel. It directly reduces the available margin and hence system capacity. Fast and accurate power control is also critical to the performance of a CDMA system because a user transmitting at higher power than is necessary to achieve a satisfactory error rate, even for a short time, reduces system capacity.

The following sections describe some of the key tests to characterize these RF power performance factors.

2.1.1 Average RF power

Average RF power will probably remain the preferred measurement for manufacturing test, even for sophisticated modulation schemes such as CDMA; but for any modulated signal, average RF power is only part of the picture. In the research and development phase, engineers are interested in peak power, peak to average power ratio (PAR), and, particularly for CDMA, power statistics such as the complementary cumulative distribution function (CCDF)—described later in the chapter. Relatively recently, power meters and analyzers have started to provide these additional measurements.

It is instructive to take a brief look at some of the power meter and sensor design challenges presented by high-bandwidth modulated RF signals. For a more detailed explanation see [13].

The most common sensor technologies used for general use are thermocouple and diode sensors. Thermocouple sensors are heat-based sensors, so they are true averaging detectors regardless of the bandwidth or modulation complexity of the signal. Their dynamic range, however, is limited to 50 dB maximum. They also take longer to settle before measurements are accurate. Therefore, they are not good for pulse (peak power) measurements.

Diode sensors use the square law part of a diode's transfer characteristic as a detector (see figure 11).

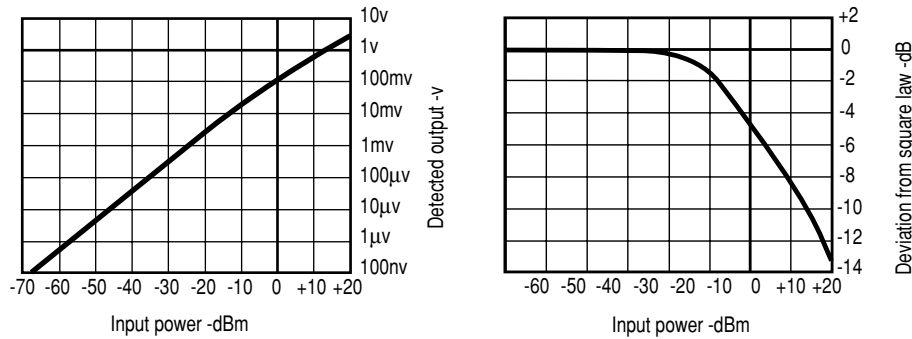

Figure 11. The diode detection characteristic ranges from square law, through a transition region, to linear detection

By employing post-detection correction techniques, the transition and linear parts of the diode's characteristic can also be used for detection. This results in a larger dynamic range, typically 90 dB, from -70 to $+20$ dBm. However, when the signal is above the square law region (typically -20 dBm), this approach is only accurate for continuous wave (CW) signals.

Alternatively, diode power sensors have recently been developed that achieve a true square law response over the whole dynamic range [14]. This alternative ensures accurate average RF power measurement for any bandwidth of signals within the frequency range of the sensor.

The major advantage of the power meter approach is accuracy over a wide dynamic range, down to a few tenths of a dB, provided care is taken while performing the measurement. It also provides measurement traceability to national standards. A potential disadvantage is that, since the power meter makes broadband measurements, you need to make sure that unwanted signals are not included.

The other solution is to measure average power using a signal analyzer with a channel power measurement. The amplitude accuracy in this case depends on the instrument. For some analyzers, the absolute amplitude accuracy is as low as 0.6 dB (similar to the power meter's accuracy). For others, the accuracy can be more than ± 1 dB, though the relative accuracy is usually much better than ± 1 dB. An advantage of the analyzer approach is that it often provides a much larger suite of measurements, including modulation quality analysis.

2.1.2 Adjacent channel interference

Depending on the context, the acronym ACP(R) has been taken to mean either adjacent channel power (ratio), which is a transmitter measurement or adjacent channel protection (ratio), which is a receiver measurement. To resolve this ambiguity, 3GPP has introduced three new terms: adjacent channel leakage power ratio (ACLR), adjacent channel selectivity (ACS), and adjacent channel interference ratio (ACIR).

ACLR is a measure of transmitter performance. It is defined as the ratio of the transmitted power to the power measured after a receiver filter in the adjacent RF channel. This is what was formerly called adjacent channel power ratio.

ACS is a measure of receiver performance. It is defined as the ratio of the receiver filter attenuation on the assigned channel frequency to the receiver filter attenuation on the adjacent channel frequency.

ACIR is a measure of overall system performance. It is defined as the ratio of the total power transmitted from a source (BTS or UE) to the total interference power resulting from both transmitter and receiver imperfections affecting a victim receiver. ACIR is mainly of interest in network simulation where the total amount of interference, rather than the source of the interference, is the primary concern. This is what was formerly called adjacent channel protection ratio.

The following equation shows the relationship between ACIR, ACLR, and ACS:

$$ACIR = \frac{1}{\frac{1}{ACLR} + \frac{1}{ACS}}$$

The main source of adjacent channel leakage (ACL) is non-linear effects in the power amplifiers (PA). It directly affects the co-existing performance of systems on adjacent channels. Power leakage is a general noise pollution and degrades performance of the system in the adjacent channel. If sufficiently bad, it causes the so called “near-far” problem, where a UE simply cannot communicate with a far away BTS because of high ACL from a nearby adjacent channel UE. Network planning can address this problem, but the associated costs depend directly on the stringency of the ACLR specification. So, we have conflicting needs. From an equipment design perspective, a relaxed ACLR specification is attractive, whereas from a network planning perspective, low ACL is very desirable.

There has been much discussion of this within the specifications committee. The current values in the 3GPP specifications for the UE are 33 dB (or -50 dBm, whichever represents a lower leakage power) at 5 MHz offset and 43 dB (or -50 dBm, whichever represents a lower leakage power) at 10 MHz offset [12].

ACLR (or ACPR) is commonly measured using a signal analyzer or measuring receiver. In the measurement, filtering is applied to both the power in the main frequency channel and the power in the adjacent channel. An important factor for ACLR is the specification of the measurement filter, including its bandwidth and shape. Original W-CDMA specifications called for a rectangular filter, but this has now changed to a root raised cosine (RRC) filter with a -3 dB bandwidth equal to the chip rate [12]. This provides a closer indication to real-life performance. However, it requires the measuring instrument to apply precise filter weighting. This may preclude making the measurement with existing spectrum analyzers that do not have W-CDMA ACLR capability, although, in reality, the difference in the measurement result is very small (around 0.1 dB). Figure 12 shows an ACLR measurement for a W-CDMA UE transmitter. The measurement was performed using a vector signal analyzer with the appropriate RRC filter, as specified.

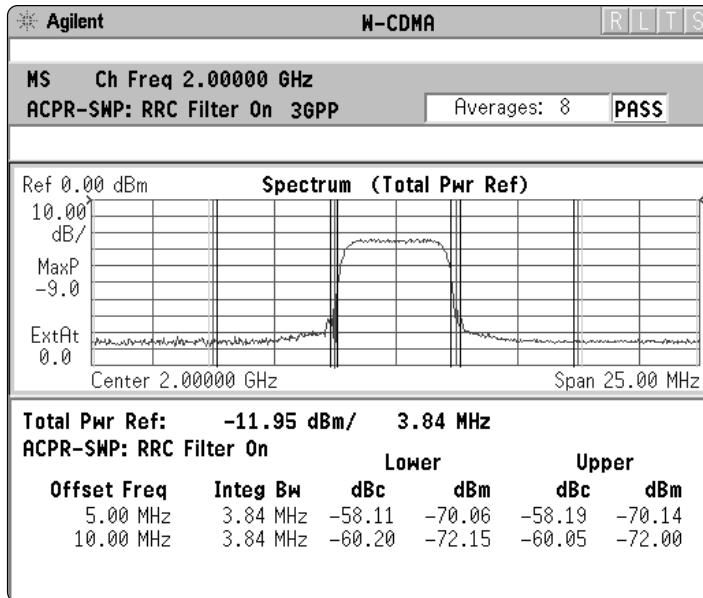

Figure 12. ACLR measurement for W-CDMA UE transmitter using a RRC filter as specified [12]

2.2 Maximizing battery life

ACLR is a key parameter, but why is it a particular challenge to maintain good ACLR performance for a W-CDMA UE?

In mobile communications, battery life is one of the most important characteristics of the handset. The efficiency of the power amplifier is key to maximizing battery life. Gaussian minimum shift keying (GMSK), used in GSM, has the advantage of having a constant amplitude envelope, which allows the use of less expensive, non-linear, class B power amplifiers (PA).

W-CDMA, on the other hand, uses a non-constant amplitude scheme, forcing the use of more expensive, less efficient, linear amplifiers. For W-CDMA, the PAR of the signal is a concern. The PAR is defined as the ratio of the peak envelope power to the average envelope power of a signal. A signal with a high PAR requires more headroom in the amplifier, which makes it less efficient. 2G non-constant amplitude formats, such as $\pi/4$ DQPSK (differential quadrature phase shift keying, used in PDC), minimize the PAR by avoiding signal envelope transitions through zero.

In W-CDMA the UE can transmit multiple channels to accommodate the high data rates. QPSK is used in combination with a spreading/scrambling function (HPSK) to minimize the PAR [8]. With this technique, the PAR for the basic configuration (one DPDCH and one DPCCH) is equal or larger than 3.6 dB during 0.1 percent of the time (see figure 13).

However, even though HPSK reduces the PAR, the PAR still increases as code channels are activated. The worst case scenario would be when five or six channels are required (see code domain power section). Although, it is expected that this will only happen a small percentage of the time, it is still critical.

Both the amplifier designer and the system integrator must make sure that the PA (and other components) can handle the PAR that the signal exhibits for the different data rates, while maintaining a good ACL performance. You can use the complementary cumulative distribution function to help you with this job.

2.2.1 Complementary cumulative distribution function

The complementary cumulative distribution function (CCDF) fully characterizes the power statistics of a signal [15]. It provides PAR versus probability. Figure 13 shows the CCDF curves for two UL W-CDMA signals with different channel configurations. For a probability of 0.1 percent, the PAR of the signal with one DPCCH and five DPDCH is 2.85 dB higher than that of the signal with one DPCCH and one DPDCH.

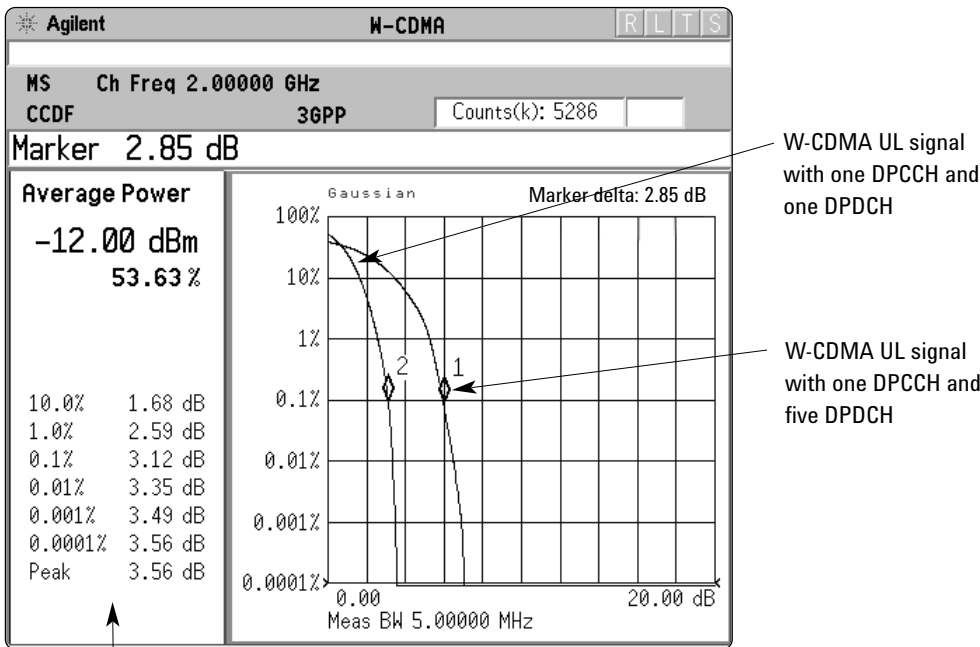

PAR values for W-CDMA UL signal with one DPCCH and one DPDCH

Figure 13. CCDFs of an UL W-CDMA signal with a DPCCH and a DPDCH and an UL W-CDMA signal with a DPCCH and five DPDCHs

CCDF curves can help you in several situations:

- To determine the headroom required when designing a component [15].
- To confirm the power statistics of a given signal or stimulus. CCDF curves allow you to verify if the stimulus signal provided by another design team is adequate. For example, RF designers can use CCDF curves to verify that the signal provided by the digital signal processing (DSP) section is realistic.
- To confirm that a component design is adequate or to troubleshoot your subsystem or system design, you can make CCDF measurements at several points of a system. For example, if the ACLR of a transmitter is too high, you can make CCDF measurements at the input and output of the PA. If the PA design is correct, the curves will coincide. If the PA compresses the signal, the PAR of the signal is lower at the output of the PA (figure 14).

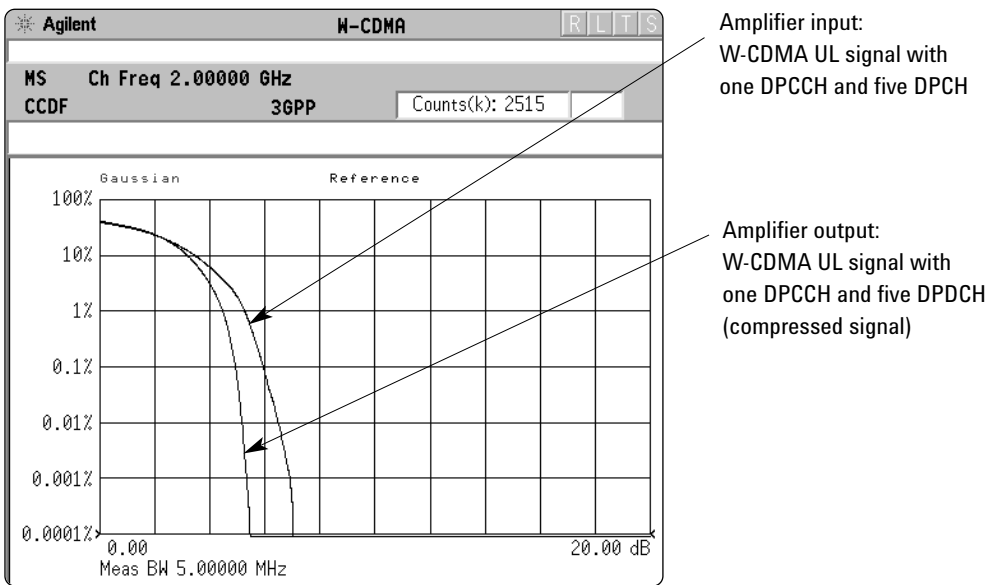

Figure 14. CCDFs for a W-CDMA signal with a DPCCH and five DPDCH, with and without compression

2.3 Measuring modulation accuracy

In constant amplitude modulation schemes, such as GMSK, the phase and frequency error are the metrics for modulation quality. However, these metrics are not very effective for non-constant amplitude modulation formats that can also have errors in amplitude.

The accuracy of non-constant amplitude modulation schemes, such as quadrature amplitude modulation (QAM), or quadrature phase shift keying (QPSK), can be assessed very effectively by looking at the constellation of the signal. Signal impairment can be objectively assessed by taking the displacement of each measured symbol from the reference position as an error phasor (or vector), as shown in figure 15.

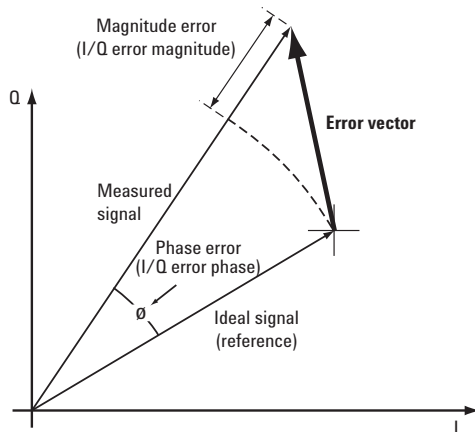

Figure 15. Error vector and related parameters

The reference position is determined from a reference signal that is synthesized by demodulating the data bits from the received signal and then remodulating these bits "perfectly" for a generic QPSK signal, as shown in figure 16.

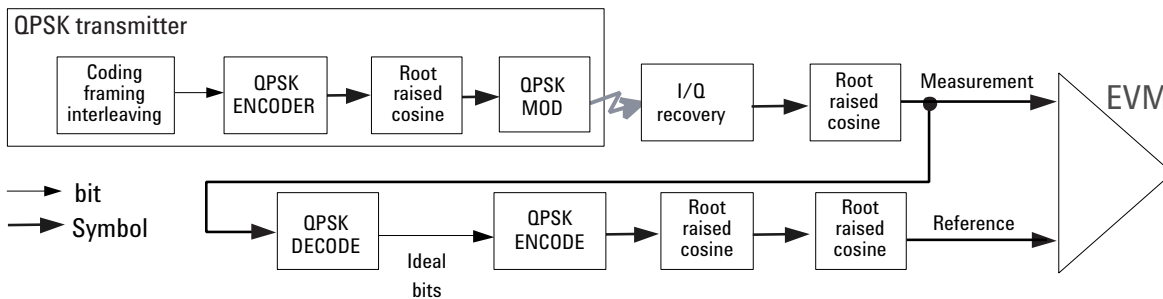

Figure 16. Process to calculate EVM for a generic QPSK signal

The root mean square (RMS) of the error vectors is computed and expressed as a percentage of the square root of the mean power of the ideal signal¹. This is the error vector magnitude (EVM). EVM is a common modulation quality metric widely used in digital communication systems. (See [16] for more information on how to use EVM as a troubleshooting tool.)

When we consider evaluating the modulation accuracy of W-CDMA it becomes evident that this explanation of EVM, while sufficient for ordinary QPSK or QAM, needs further elaboration. Should we measure the EVM at the chip level or at the symbol level? Should we measure EVM for a signal with a single DPDCH channel or with another channel configuration? How do we calculate the reference?

1. The actual calculation method of the percentage depends on the specific standard. The EVM may be normalized to the amplitude of the outermost symbol, the square root of the average symbol power, or the square root of the mean power of the ideal signal. In the case of W-CDMA, the specifications require normalization to the square root of the mean power of the ideal signal (see section on Composite EVM).

The following sections explain the differences between the various EVM and other modulation quality measurements that you can perform on a W-CDMA signal and when they should be used. Figures 17, 19, and 27 show the processes to make the different measurements.

2.3.1 QPSK EVM

For a regular QAM or a PSK signal, the ideal symbol points always map onto a few specific locations in the I/Q plane. However, the W-CDMA UL signal can consist of multiple channels that are I/Q multiplexed. This means the bits for each channel are binary phase shift keying (BPSK) encoded¹ for either the I or the Q paths. Several channels can be added to the I and/or the Q paths. The resulting I and Q signals are then spread and scrambled with a special function (HPSK) (see figure 9).

The complex-valued chip sequence is then filtered with an RRC ($a = 0.22$) filter and the result is applied to the QPSK² modulator. The UE transmitter in figure 17 illustrates this process.

The resulting constellation depends on the physical channel configuration. The constellation typically does not look like QPSK, or any other known constellation, except for some very specific channel configurations. For example, a signal with a single DPDCH (or a single DPCCH) does map onto a QPSK constellation. A signal with a DPDCH and a DPCCH at the same amplitude level maps onto a 45°-rotated QPSK constellation, as shown in figure 18. Because the receiver does not care about the absolute phase rotation, it effectively sees a QPSK constellation.

You can use a regular QPSK EVM measurement to evaluate the modulation quality of the transmitter for a single DPDCH, a single DPCCH, or a signal with both at the same amplitude level. More complex signals cannot be analyzed with this measurement. QPSK EVM compares the measured chip signal at the RF with an ideal QPSK reference (see figure 17).

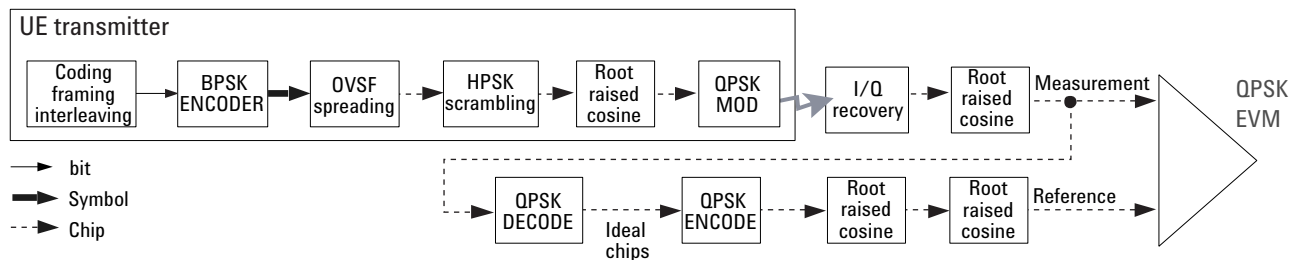

Figure 17. Process to calculate QPSK EVM for a W-CDMA UL signal

The QPSK EVM measurement does not descramble and despread the signal into symbols and back into chips to calculate the appropriate reference. Therefore, it can detect baseband filtering, modulation, and RF impairments, but does not detect OVSF spreading or HPSK scrambling errors.

1. BPSK encoding, in this case, refers to the process of mapping the bits for a channel onto the I (or the Q) path in serial. This means that the bits for a channel are directly converted into I (or Q) amplitude levels. For example, 1001 would be converted to 1 -1 -1 1.
2. QPSK modulation, in this case, refers to the up conversion process of modulating the RF carrier with the I/Q baseband signal.

If it is impossible to despread and descramble the signal, the QPSK EVM measurement may be the only choice. In this sense, the QPSK EVM measurement can be useful to RF designers or system integrators to evaluate the modulation quality of the analog section of the transmitter when the spreading or scrambling algorithms are not available or do not work properly. For example, figure 18 shows the QPSK EVM measurement and vector diagram for a W-CDMA UL signal (one DPDCH and a DPCCH at the same power level) with and without an I/Q quadrature error.

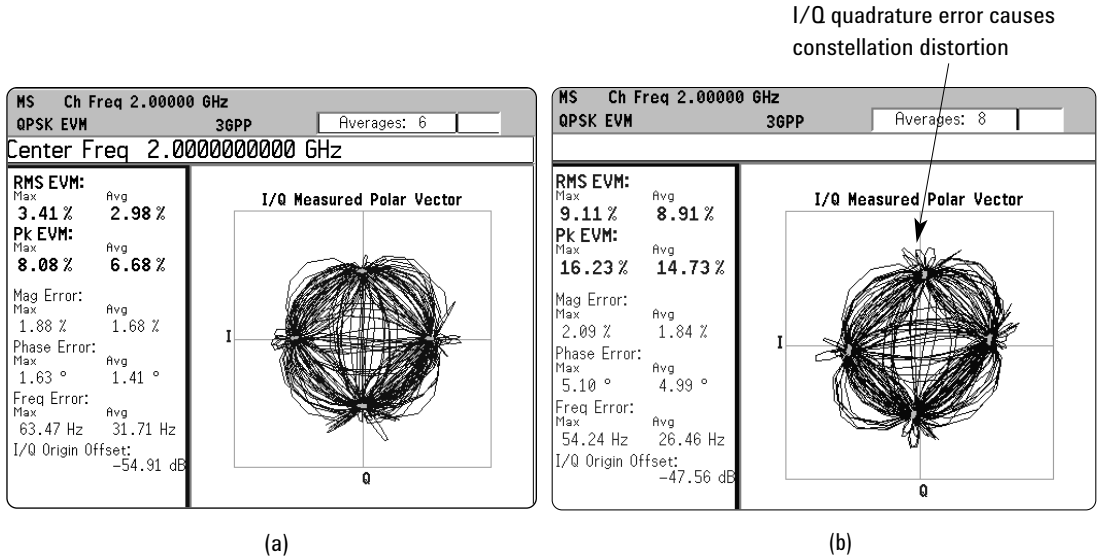

Figure 18. Vector diagram and QPSK EVM measurement for an UL W-CDMA signal (one DPDCH and one DPCCH at the same amplitude level). (a) Transmitter without any impairment. (b) Transmitter with an I/Q quadrature error.

Depending on the nature of the error, you can use the vector diagram, the error vector versus time or frequency, the magnitude error versus time, or the phase error versus time to troubleshoot it. For example, most I/Q impairments (such as the I/Q quadrature error in figure 18) can be easily recognized by looking at the vector diagram. In-channel spurious signals can be detected by analyzing the error vector spectrum [16].

2.3.2 Composite EVM

Although measuring EVM for a signal with a single DPDCH (or a DPDCH and a DPCCH) may be useful, in general, we are interested in the overall modulation quality of the transmitter for any channel configuration. The constellation of this signal will vary depending on its channel configuration. The measurement of choice in this case is the composite EVM measurement. It corresponds to the modulation accuracy conformance test specified in the 3GPP specifications [12].

To evaluate the modulation accuracy of a W-CDMA multi-channel UL signal, we again need to synthesize a reference signal. The signal under test is downconverted (the baseband I and Q signals are recovered) and passed through a root raised cosine receiver filter. Active channels are descrambled, despread, and the BPSK is decoded to bits (see figure 19).

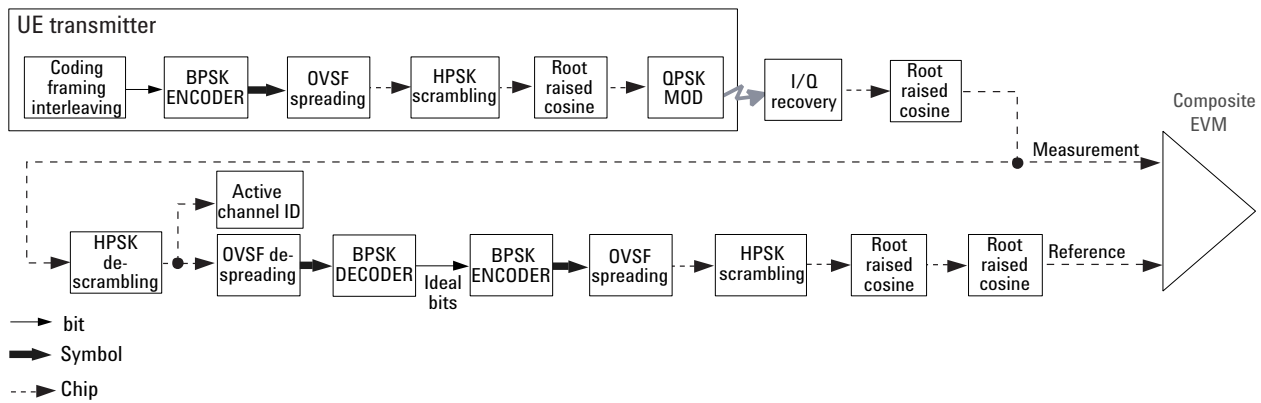

Figure 19. Process to calculate the composite EVM

The despread bits are "perfectly" remodulated to produce the required reference signal at the chip level. The reference signal is then subtracted from the measured signal to produce a time record of error phasors. The square root of the ratio of the mean power of the error signal to the mean power of the reference signal is computed and expressed as a percentage EVM.

The composite EVM measurement accounts for all spreading and scrambling problems in the active channels and for all baseband, IF, and RF impairments in the transmitter chain.

A coded signal with the DPCCH and at least one DPDCH is required to make a composite EVM measurement on a W-CDMA UL signal. Otherwise, the analyzer cannot demodulate the signal and calculate the appropriate reference. In this case, you can use QPSK EVM to measure the RF performance for limited channel configurations, as mentioned earlier.

There are several situations where you will want to use the composite EVM measurement (and its related vector diagram, phase error and magnitude error metrics, etc.), instead of a QPSK EVM measurement:

- 1. To evaluate the quality of the transmitter for a multi-channel signal.** This is particularly important for RF designers, who need to test the RF section (or components) of the transmitter using realistic signals with correct statistics. In general, the peak-to-average power ratio of the signal increases as the number of channels increases. By measuring modulation quality on a multi-channel signal you can analyze the performance of the RF design for W-CDMA UL signals with different levels of stress (different CCDFs). Evaluating the modulation quality of multi-channel signals is also important for the baseband designers to analyze the performance of multi-board baseband designs. For example, a small timing error in the clock synchronization between channels on different boards can be detected as a decrease in modulation quality. Figure 20a shows the composite EVM and vector diagram for the UL 12.2 kbps reference measurement channel, as required by the modulation accuracy test in the 3GPP specifications [12]. Figure 20b shows the composite EVM and vector diagram for a signal with the DPCCH and three DPDCHs.

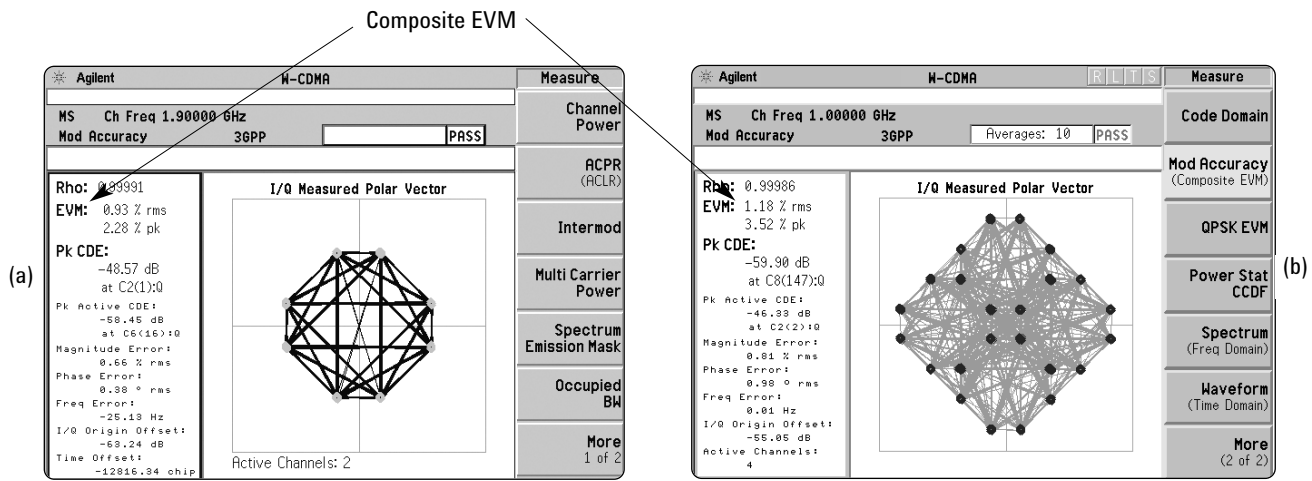

Figure 20. Composite EVM and vector diagram for a signal with (a) UL 12.2 kbps reference measurement channel (one DPDCH and a DPCCH), and (b) three DPDCHs and a DPCCH.

2. **To detect spreading or scrambling errors.** Depending on the degree of the error, the analyzer may show an intermittent unlock condition or may not be able to lock at all when trying to perform a composite EVM measurement. This is mainly useful to system integrators to determine errors in the spreading and scrambling. If this problem occurs, you can use the QPSK EVM measurement to confirm that the rest of the transmitter is working as expected. If the scrambling or spreading error does not cause an unlock measurement condition, you can use the error vector versus time display to find the problematic chip.
3. **To detect certain problems between the baseband and RF sections.** This is mainly useful for system integrators. You may be able to use QPSK EVM measurement to detect some of these problems. For example, LO instability caused by interference from digital signals can be detected with QPSK EVM. However, the QPSK EVM measurement will not detect problems that require the measurement to synchronize with a bit sequence. For example, I/Q swapped (reversed I and Q) errors will look perfectly normal if a QPSK EVM measurement is used. On the other hand, it will cause an unlock condition when performing a composite EVM measurement.
4. **To analyze errors that cause high interference in the signal.** If the interference is too high, the QPSK EVM measurement may not be able to recover the true ideal reference. In this case, the QPSK EVM and its related displays are not accurate. Since the composite EVM measurement descrambles and despreads the signal, it takes advantage of its spreading gain. This allows it to recover the true reference even when the signal is well beyond the interference level that will cause multiple chip errors. Therefore, composite EVM is a true indicator of modulation fidelity even when the signal under test is buried by interference. In this sense, the measurement may be particularly useful in hostile field environments with high levels of interference. System integrators can use the composite EVM measurement to analyze the quality of the UE at the system level. By applying external interference to the signal transmitted by the UE, you can evaluate how bad the EVM can get before the signal analyzer cannot recover the signal. This allows you to verify what the minimum modulation accuracy for the UE transmitter should be in order for the BS to demodulate the signal in realistic field environments. The spreading gain benefits of composite EVM can also be useful to RF designers and system integrators for occasional bad cases of interference. For example, figure 21a shows the

phase error versus time display for a QPSK EVM measurement for a signal with a DPCCH and a DPDCH at the same level. The signal has a very high LO instability and the analyzer is not able to recover the correct reference. Figure 21b shows the phase error versus time for a composite EVM measurement for the same signal. In this case, the analyzer can demodulate the signal and calculate the reference accurately. The phase error display in figure 21b will allow you to analyze the interference.

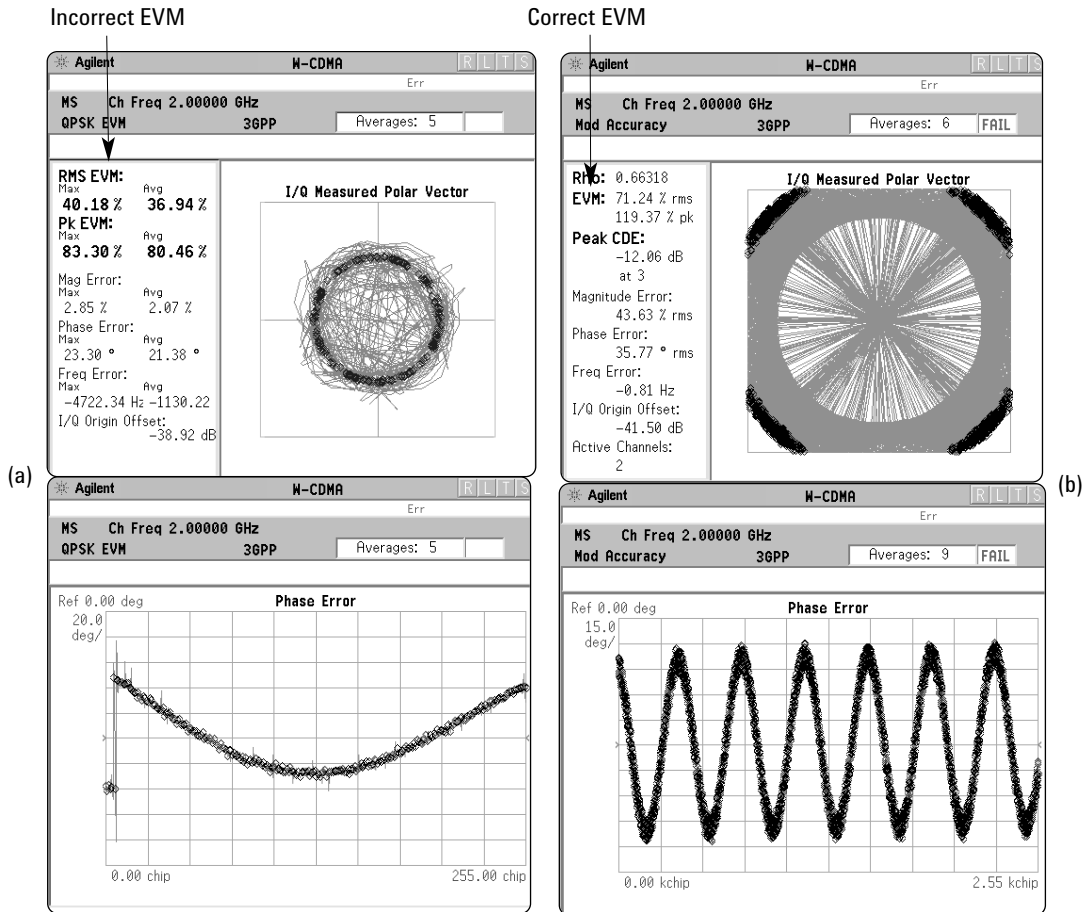

Figure 21. W-CDMA UL signal with one DPDCH and a DPCCH at the same amplitude. Signal with very high LO instability. (a) Vector diagram and phase error versus time for a QPSK EVM measurement. (b) Vector diagram and phase error versus time for a composite EVM measurement.

Composite EVM is useful throughout the development, performance verification, and manufacturing phases of the UE life cycle as a single figure of merit for the composite waveform as a whole. You will also be interested in the code-by-code composition of the multiplex. The primary means of investigating this is to look at the distribution of power in the code domain.

2.3.3 Code domain power

Code domain power is an analysis of the distribution of signal power across the set of code channels, normalized to the total signal power. To analyze the composite waveform, each channel is decoded using a code-correlation algorithm. This algorithm determines the correlation coefficient factor for each code. Once the channels are decoded, the power in each code channel is determined.

In W-CDMA, the measurement is complicated by the fact that the length of the OVSF codes, or SF, varies to accommodate the different data rates. As the user rate increases the bit period becomes shorter. Since the final chip rate is constant, fewer OVSF code chips are accommodated within the bit period—the SF becomes smaller. The SF can be 4, 8, 16, 32, 64, 128, or 256, corresponding to DPDCH bit rates from 960 kbps down to 15 kbps¹.

Seven sets of spreading codes are specified, one set for each SF. The OVSF codes can be allocated using the code tree in figure 22. Each code is denoted by $C_{ch,SF,n}$. For example, $C_{ch,4,2}$ means channelization code, SF = 4, code number 2.

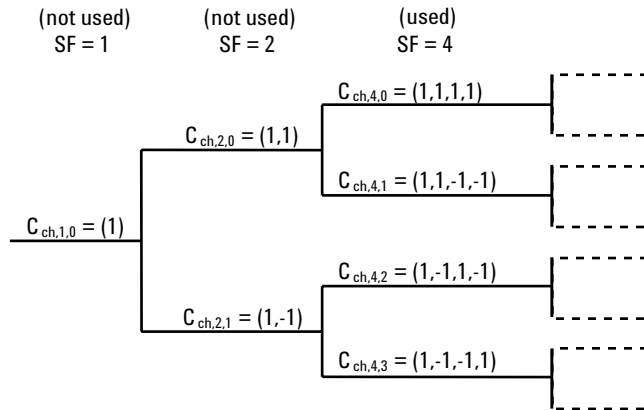

Figure 22. Code tree generation of OVSF codes [3]

In this tree, OVSF codes of a certain SF are obtained by copying the “mother-branch” code of the previous SF and repeating or inverting it. For example, $C_{ch,4,2} = (1,-1,1,-1)$ is obtained by repeating $C_{ch,2,1} = (1,-1)$, while $C_{ch,4,3} = (1,-1,-1,1)$ is obtained by copying $C_{ch,2,1} = (1,-1)$ and inverting it. This code generation technique is known as reverse-bit method.

One of the consequences of using variable SFs is that a shorter code precludes using all longer codes derived from it. Figure 23 illustrates this concept. If a high data rate channel using a code of SF = 4 (1, 1, -1, -1) is selected, all lower data rate channels using longer OVSF codes that start with 1, 1, -1, -1 have to be inactive because they are not orthogonal.

1. The bit rate for the DPCC is fixed at 15 kbps.

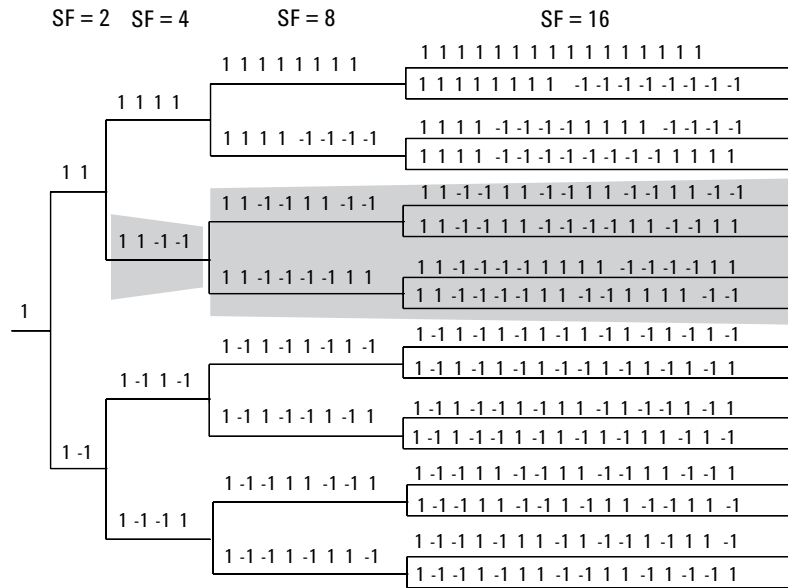

Figure 23. Effects of using variable SFs

For the UL, as shown earlier, the physical channels are I/Q multiplexed. A special scrambling function (HPSK) is applied to limit the PAR. However, HPSK limits the choice of OVFSF codes. In order to benefit from HPSK, the OVFSF codes must consist of pairs of consecutive identical chips. For example, $C_{ch,4,1} = (1,1,-1,-1)$ would meet this condition, but $C_{ch,4,2} = (1,-1,1,-1)$ would not [8].

Careful choice of OVFSF codes can lead to lower PAR. Exhaustive simulations using CCDF curves (see earlier section) led to the following specifications for the OVFSF codes [9]:

- The DPCCH is always spread by code $C_{ch,256,0} = (1,1,1,1,1, \dots)$.
- When only one DPDCH is to be transmitted, it is spread by code $C_{ch,SF,SF/4} = (1,1,-1,-1,1,1,-1,-1, \dots)$.
- When more than one DPDCH is to be transmitted (because of high data rates), all DPDCHs have SFs equal to four. Two DPDCHs can share the same code, since one will be in I and the other one in Q, which makes them orthogonal. The channelization codes for the DPDCHs are defined as:

- $C_{ch,4,1} = (1,1,-1,-1)$ for the first and second DPDCHs
- $C_{ch,4,3} = (1,-1,-1,1)$ for the third and fourth DPDCHs
- $C_{ch,4,2} = (1,-1,1,-1)$ for the fifth and sixth DPDCHs

Even though the OVFSF codes were selected to maximize the benefits of HPSK, the HPSK requirements will be completely fulfilled only for the first two DPDCHs. The worst case of PAR will be when five or six channels are required to cover the high data rates. It is expected that this will only occur a small percentage of the time. However, this does not make solving the problem easier for the amplifier designer.

In terms of code capacity, channels with higher data rates (lower SF) occupy more code space. For example, $C_{ch,4,1}$ occupies two times more code space than $C_{ch,8,2}$, and four times more code space than $C_{ch,16,4}$. The wider bars in the code domain power display represent codes with low SF that occupy more code space. Figure 24 shows the code domain power display for a signal with a DPCCH and three DPDCHs. The three DPDCH (at 960 kbps, SF = 4) are much wider than the DPCCHs (at 15 kbps, SF = 256). In order to provide this display, the analyzer must be able to identify the SFs of the code channels being measured.

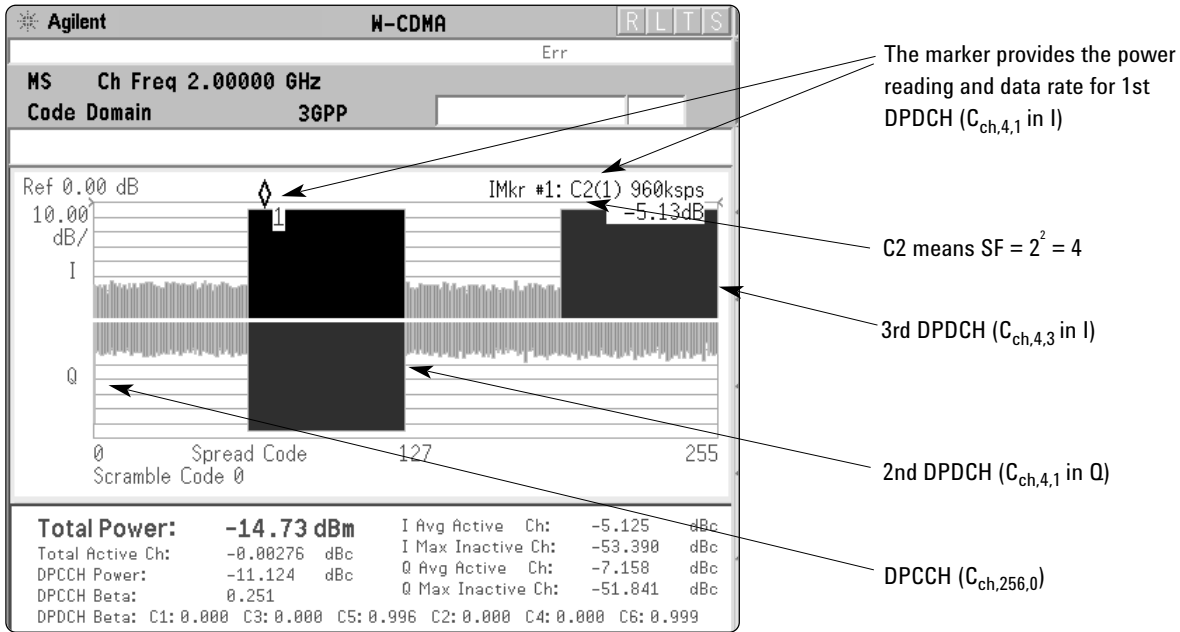

Figure 24. Code domain power of W-CDMA UL signal with a DPCCH and three DPDCHs

The code domain power measurement helps you not only verify that each OVSF channel is operating at its proper amplitude, but also identify problems throughout the transmitter design from the coding to the RF section. In particular, the levels of the inactive channels can provide useful information about specific impairments. Ideally, the levels for the inactive channels would be zero. In reality, signal and system imperfections compromise the code orthogonality and result in a certain amount of signal power projecting onto inactive codes. A real signal will also have a certain noise level, which being random, will project more or less evenly onto all codes.

The projection of the error is interesting because it enables you to see how the error power is distributed in the code domain. You want the error power to be evenly distributed throughout the code domain, rather than concentrated in a few codes, to avoid code-dependent channel quality variations.

One possible cause of uneven distribution of error power is LO instability. In essence, energy is lost from the active channels and appears in those channels with codes that are closely related to the active channel codes [16]. In the case of OVSF codes, this results in higher code domain noise for channels with code assignments consecutive to the active channel code, whether they are at the same or at a different I/Q path. Figure 25 shows the code domain power display for the UL 768 kbps reference measurement channel (1 DPCCH and 2 DPDCHs) signal with a phase noise problem.

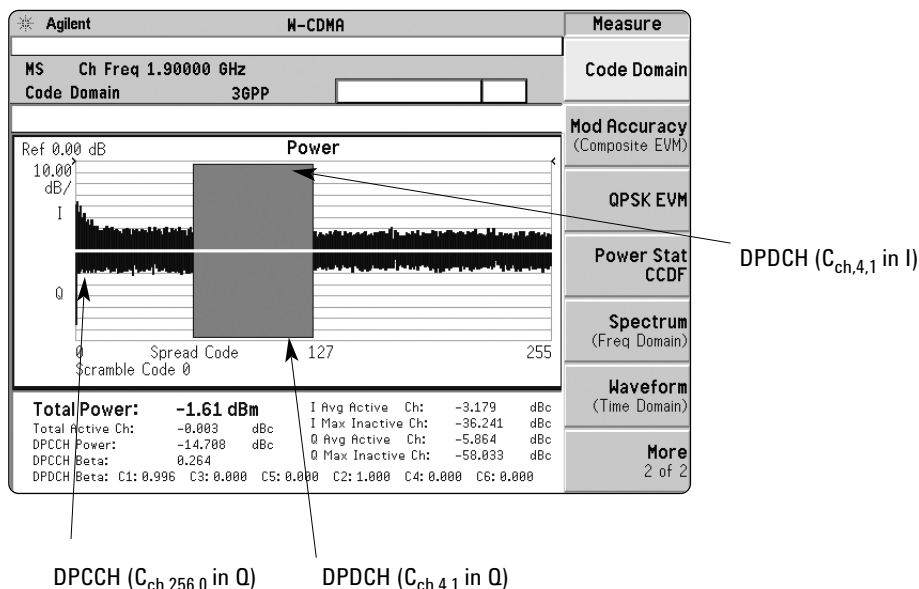

Figure 25. Code domain power measurement for the UL 768 kbps reference measurement model (one DPCCH and two DPDCHs). Signal with high LO instability.

2.3.4 Peak code domain error

In W-CDMA, specifically to address the possibility of uneven error power distribution, the composite EVM measurement has been supplemented by another test called peak code domain error that specifies a limit for the error power in any one code.

This test is only required for the UE in which multi-code transmission is provided. The UE must be configured with the UL 768 kbps reference measurement channel (which is the only UL reference measurement channel with two DPDCHs). The error vector power must be projected on each code channel with a SF of 4. The peak code domain error is then calculated from the code that returns the largest error power relative to the composite reference signal. The error must not exceed -15 dB. Figure 26 shows the peak code domain error, in combination with the composite EVM, for the same signal (UL 768 kbps reference measurement channel) with the LO instability problem above. In this case, the peak code domain error falls in an active code channel. The result of the measurement coincides with the peak active code domain error, which calculates the error only in the active code channels.

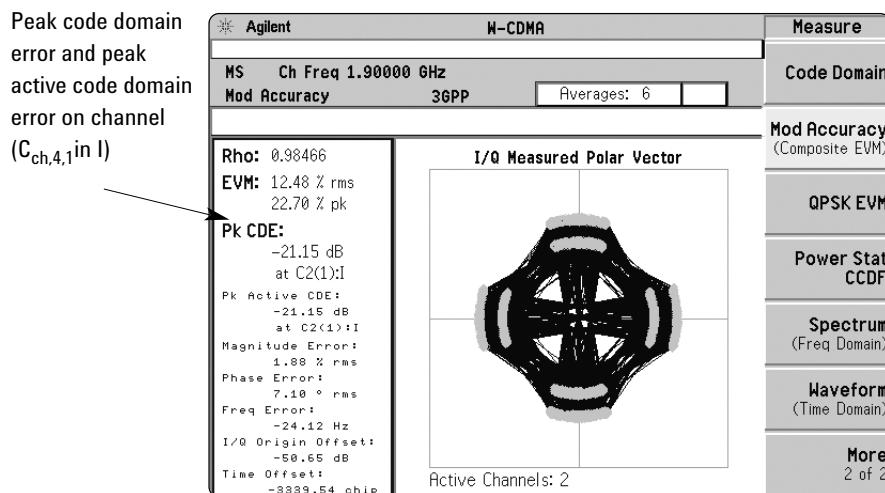

Figure 26. Peak code domain error and composite EVM display for the UL 768 kbps reference measurement model (one DPCCH and two DPDCHs). Signal with high LO instability.

Apart from looking at the code domain power and peak code domain error, it is useful to analyze a specific code channel. The following sections describe some analysis tools and how they can be applied. Figure 27 shows how these measurements are calculated.

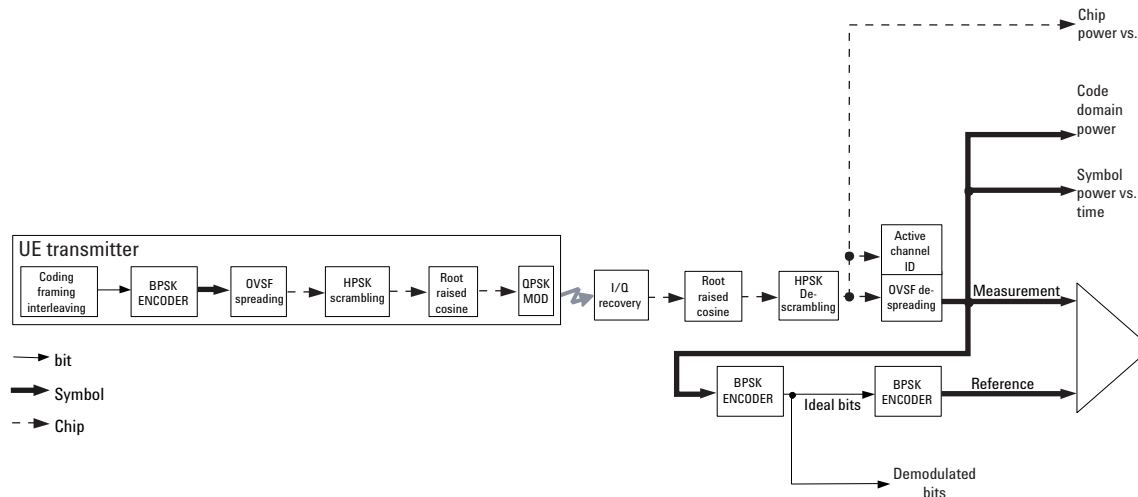

Figure 27. Process to calculate code domain power, symbol EVM, symbol power versus time, chip power versus time, and demodulated bits

2.3.5 Symbol EVM

By descrambling and despreding the signal you can analyze the constellation and EVM for a specific code channel at the symbol level, even in the presence of multiple codes. The measured signal is HPSK descrambled and despread. The phase trajectory of the ideal symbol reference is then calculated and compared to the trajectory of the measured despread symbols (figure 27).

An impairment that affects symbol EVM will also affect the composite EVM. For example, an amplifier compression problem will appear both in the composite EVM and in the symbol EVM measurement. However, because of the spreading gain symbol EVM will mute the impairment. So why use symbol EVM?

Symbol EVM provides the bridge between RF and demodulated bits. Since it includes the spreading gain, it provides a measure of modulation quality closer to real-life performance. In this sense, you can think of symbol EVM as the actual quality the user in that channel will experience (similar to the reciprocal of the bit error rate (BER)).

The relationship between symbol EVM and chip EVM depends on the SF. At low SFs (high data rates) chip modulation errors have a significant effect on symbol EVM. But at high SFs, chip modulation errors have little effect on symbol EVM. In this sense, it is particularly useful to baseband digital signal processing (DSP) engineers to evaluate symbol quality and analyze how specific impairments affect the quality of channels at different data rates. For example, figure 28 shows the symbol EVM for a signal with a high-frequency phase error problem, for a code channel at 15 kbps with SF = 256 ($C_{ch,256,64}$) and a channel at 480 kbps with SF = 8 ($C_{ch,8,2}$). The symbol EVM for the lower data rate channel is much lower than that of the higher data rate channel.

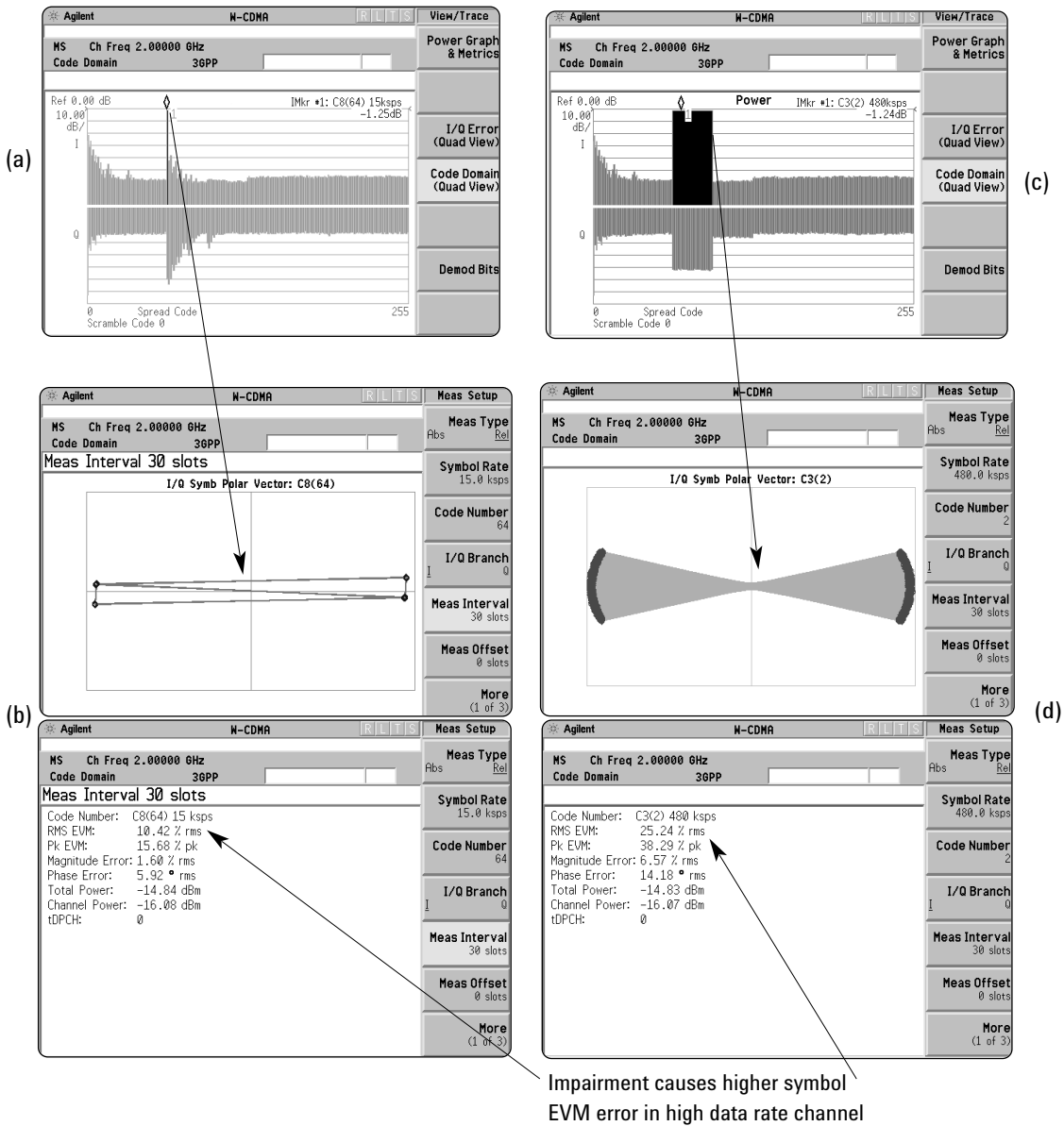

Figure 28. (a) Code domain power measurement of a W-CDMA UL signal with the DPCCH and one DPDCH at 15 kbps ($C_{ch,256,64}$) and (b) symbol EVM measurement for the DPDCH at 15 kbps ($C_{ch,256,64}$). (c) Code domain power measurement of a W-CDMA UL signal with the DPCCH and one DPDCH at 480 kbps ($C_{ch,8,2}$) and (d) symbol EVM measurement for the DPDCH at 480 kbps ($C_{ch,8,2}$).

2.3.6 Symbol power versus time

Analyzing the symbol power for a specific code channel versus time can be particularly useful to monitor the power and response of the UE power control system for different code channels (figure 29).

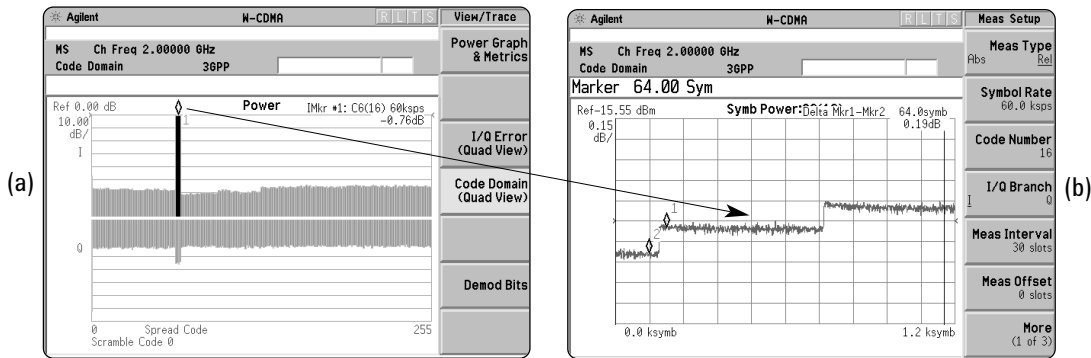

Figure 29. (a) Code domain power measurement of a W-CDMA UL signal with the DPCCH and one DPDCH at 60 kbps ($C_{ch,64,16}$) and (b) symbol EVM measurement for the DPDCH ($C_{ch,64,16}$).

Figure 30 shows the despread symbol power in combination with the composite (total) chip power for an UL signal. Chip power represents the total power of the signal at the chip rate. Analyzing the symbol power for a channel in combination with the total chip power versus time is particularly useful for system integrators to analyze the power amplifier response (ripple) to a power control command.

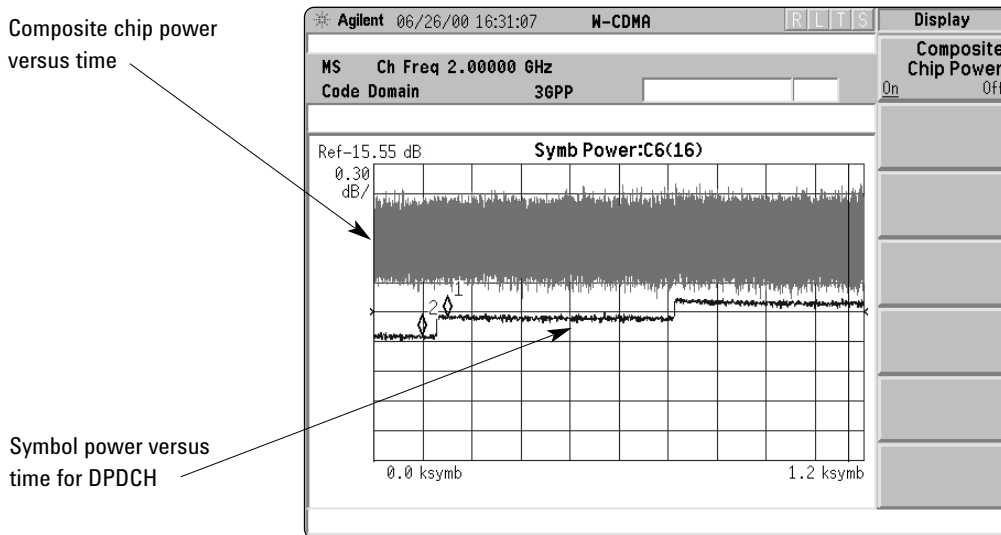

Figure 30. Chip power versus time for a W-CDMA UL signal with the DPCCH and one DPDCH at 60 kbps ($C_{ch,64,16}$), combined with symbol power versus time for the DPDCH ($C_{ch,64,16}$).

2.3.7 Demodulated bits

By obtaining the demodulated bits after HPSK descrambling and despreading for each code channel (I for the DPDCH and Q for the DPCCH, for the basic configuration), the correct bit patterns can be verified. As shown in table 1, the UL DPCCH can have different slot structures. Figure 31 shows a slot structure example for a UL DPDCH and DPCCH. You can verify if the bits for the different fields (Pilot, TPC, etc.) are correct by using the demodulated bits measurement (figure 32).

Table 1. UL DPCCH fields in normal mode

Slot format #i	Channel bit Rate (kbps)	Channel symbol Rate (kbps)	SF	Bits/frame	Bits/slot	N_{pilot}	N_{TFCI}	N_{FBI}	N_{TPC}
0	15	15	256	150	10	6	2	0	2
1	15	15	256	150	10	8	0	0	2
2	15	15	256	150	10	5	2	1	2
3	15	15	256	150	10	7	0	1	2
4	15	15	256	150	10	6	0	2	2
5	15	15	256	150	10	5	2	2	1

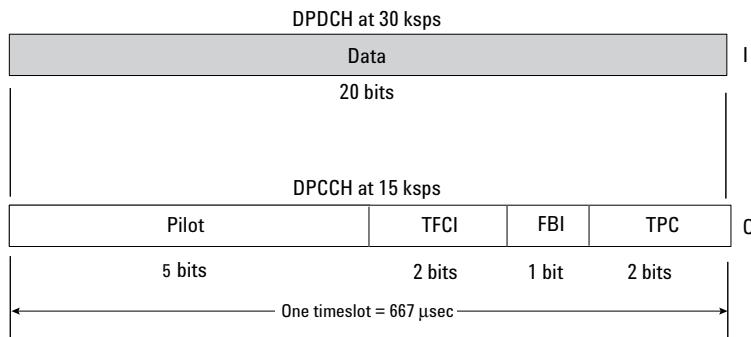

Figure 31. Example of UL DPDCH and DPCCH slot structure

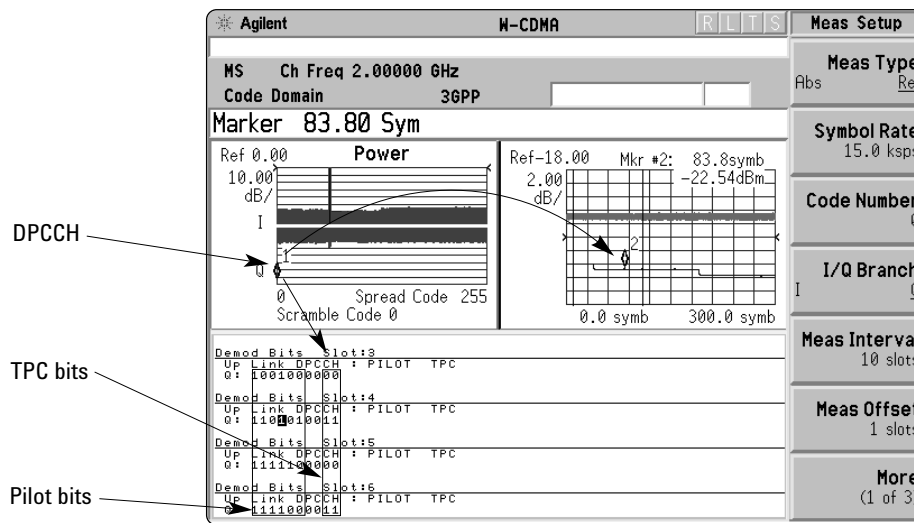

Figure 32. Demodulated bits for the DPCCH (slot format 0) of a W-CDMA UL signal with the DPCCH and one DPDCH at 60 kbps ($C_{ch,64,16}$)

Analyzing demodulated bits enables baseband engineers to identify coding and interleaving errors. In many cases, it can help you clarify situations where the BTS and UE are having problems communicating with each other. Analyzing the demodulated bits may verify whether the error is coming from the UE coding and interleaving, or the BTS de-interleaving and decoding process.

2.4 Measuring receiver functionality and performance

In CDMA the receiver demodulation process is more complex than in TDMA systems. The UE receiver must use correlation, descrambling, and despreading algorithms to recover the symbols for the appropriate channel from the signal transmitted by the BTS.

In the case of W-CDMA, the complexity increases by at least an order of magnitude over IS-95. Some key challenging aspects are the UE's synchronization with the BTS and ability to despread and demodulate code channels at different data rates.

The figure of merit in the 3GPP specifications is bit error rate (BER) for receiver characteristics and block error rate (BLER) for RF performance. The receiver characteristic tests include reference sensitivity level, adjacent channel selectivity (ACS), and blocking characteristics [12]. Performance tests analyze the receiver performance for the different channels under specified propagation conditions or transmission modes. Some examples of performance tests are demodulation of the dedicated channel (DCH) in multi-path fading propagation conditions and demodulation of DCH in site selection diversity transmission mode [12].

BER and BLER tests require full implementation of the UE receiver, which may not be available in the early stages of the receiver design. The following sections discuss the different tests you can perform to verify the functionality and performance of different aspects of your W-CDMA UE receiver subsystem and system design, and the stimulus signal requirements for these tests. For general information on troubleshooting digital communications receiver designs refer to [17].

2.4.1 Timeslot synchronization testing and searcher testing

In contrast with other CDMA systems, W-CDMA BTSs transmit asynchronously, as described in chapter 1. The system relies on the UE's ability to recognize the appropriate BTS and synchronize to it. Each BS is assigned a unique code for identification purposes. It uses the P-SCH and S-SCH to tell the UE which of the 64 possible code patterns this unique code belongs to, as shown in figure 33.

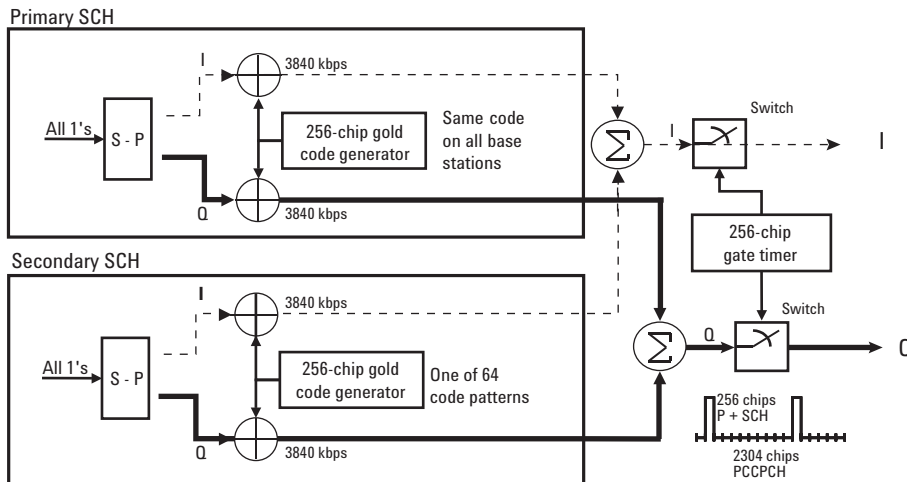

Figure 33. Physical structure for P-SCH and S-SCH

The UE must perform the following synchronization process:

1. Find and time synchronize to the P-SCH rate.
2. Find and decode the S-SCH. The BTS uses one of 512 unique scrambling codes. The UE must determine which of the 64 possible code groups is being indicated by the S-SCH. Each code group represents eight scramble codes ($64 \times 8 = 512$).
3. Begin the search for which of the eight possible scrambling codes the BTS is using within the code group defined by the S-SCH. The UE searches for this scrambling code by determining which scramble code provides the best correlation to the CPICH. The CPICH is spread by $C_{ch,256,0} = \{1,1,1,1,\dots\}$. Therefore, the scrambling code can be extracted from it. The BCH, which is carried on the P-CCPCH, contains additional timing information in the form of the system frame number (SFN). This number provides the UE with information about timing of transport block boundaries, which is critical to the decode processes.

The first step to verify the UE's synchronization functionality is to test the UE's timeslot synchronization. This test requires a stimulus signal comprising a P-SCH burst at timeslot intervals, as indicated in figure 34.

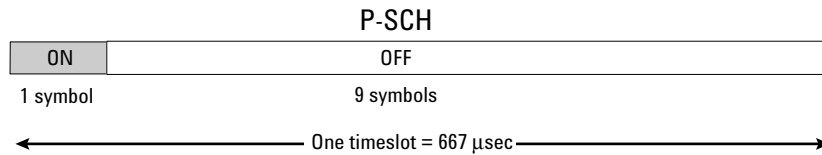

Figure 34. P-SCH timeslot structure

The second step is to verify the overall functionality of the mobile searcher, which includes synchronization, determining the scramble code group, and identifying the primary scramble code of the transmission. This test requires a stimulus signal comprising a P-SCH, a S-SCH, a P-CCPCH, and a CPICH, as shown in figure 6. The S-SCH is configured to indicate one of the 64 scramble code groups. This test should be performed for each of the 64 scramble code groups.

After verifying the functionality of the searcher, you need to verify correct recovery of the SFN from the BCH. The SFN should be increasing every 20 ms.

2.4.2 Verification of demodulation and despreading

As mentioned in chapter 1, in the DL a DPDCH is time multiplexed with a DPCCH to form a DPCH. It may be useful to verify the demodulation and despreading (processing from chips to symbols) functionality of the subsystem at various symbol rates, scramble codes (primary and secondary¹), all slot structures (for example, with and without TFCI), channel power ratios, time offsets, etc. Table 2 shows all the possible DL slot structures for a DPCH in normal mode.

Slot format #i	Channel bit rate (kbps)	Channel symbol rate (kbps)	SF	Bits/frame			Bits/slot	DPDCH Bits/slot		DPCCH Bits/slot		
				DPDCH	DPCCH	TOT		N _{data1}	N _{data2}	N _{TFCI}	N _{TPC}	N _{pilot}
0	15	7.5	512	60	90	150	10	2	2	0	2	4
1	15	7.5	512	30	120	150	10	0	2	2	2	4
2	30	15	256	240	60	300	20	2	14	0	2	2
3	30	15	256	210	90	300	20	0	14	2	2	2
4	30	15	256	210	90	300	20	2	12	0	2	4
5	30	15	256	180	120	300	20	0	12	2	2	4
6	30	15	256	150	150	300	20	2	8	0	2	8
7	30	15	256	120	180	300	20	0	8	2	2	8
8	60	30	128	510	90	600	40	6	28	0	2	4
9	60	30	128	480	120	600	40	4	28	2	2	4
10	60	30	128	450	150	600	40	6	24	0	2	8
11	60	30	128	420	180	600	40	4	24	2	2	8
12	120	60	64	900	300	1200	80	4	56	8*	4	8
13	240	120	32	2100	300	2400	160	20	120	8*	4	8
14	480	240	16	4320	480	4800	320	48	240	8*	8	16
15	960	480	8	9120	480	9600	640	112	496	8*	8	16
16	1920	960	4	18720	480	19200	1280	240	1008	8*	8	16

*If TFCI bits are not used, then discontinuous transmission (DTX) bits shall be used.

Table 2. Downlink slot structures for DPCH in normal mode

This test only requires a stimulus signal comprising a single repeating frame of a DPCH with user control of the above mentioned variables. The stimulus generator must also allow user control of the bit pattern in the data field for verification of proper despreading. If hardware synchronization is required by the receiver under test, the generator should also provide a frame clock output.

1. W-CDMA defines a secondary set of scrambling codes. These codes can be used to increase code capacity.

2.4.3 Verification of TFCI decoding and power offset effects

As shown in table 2, the DPCCCH consists of different fields. These fields can have independent amplitudes as shown in the example in figure 35. This feature provides increased protection of the power control, timing, and control bits transmitted to the UE.

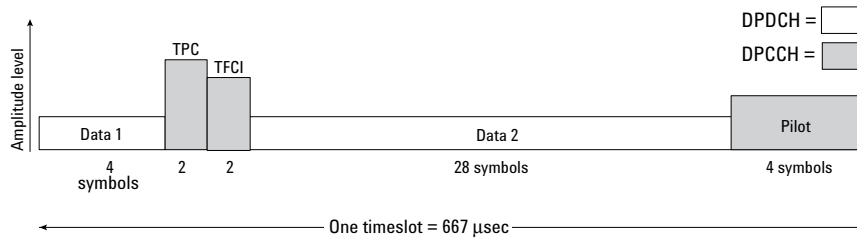

Figure 35. Example of variable power levels for DL DPCCCH fields

One of the fields in the DPCCCH is the TFCI. The TFCI informs the receiver about the DCH transport format. (If the TFCI is not available, the receiver must perform blind detection.)

It is important to determine the receiver's response to DPCCCH power offsets and its ability to properly decode the TFCI field.

This test requires a stimulus signal comprising a single repeating frame of a DPCH with user control of TFCI, TPC, and Pilot symbol power offsets, along with proper coding of the TFCI based on a variable 10-bit input, as seen in figure 36.

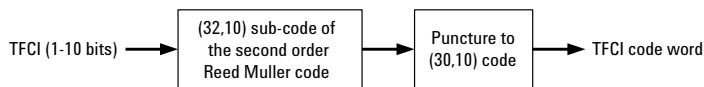

Figure 36. TFCI coding

2.4.4 Verification of response to TPC commands

As mentioned earlier, fast and accurate power control is critical to ensure maximum system capacity. The BTS uses the TPC bits in the DPCCCH to tell the UE to increase or decrease the code channel power of that particular user. Testing the accuracy of the response of the UE code channel power to TPC commands is one of the conformance tests for the transmitter [12]. Performing this test analyzes not only the accuracy of the transmitter's response but also verifies the ability of the receiver to decode the power control bits.

In order to determine the UE response to TPC commands as required by the 3GPP specifications, the source must generate a DPCH with user control of the TPC pattern [12]. The source is also required to support a ramp pattern of several sequences of steps up and down, as shown in figure 37.

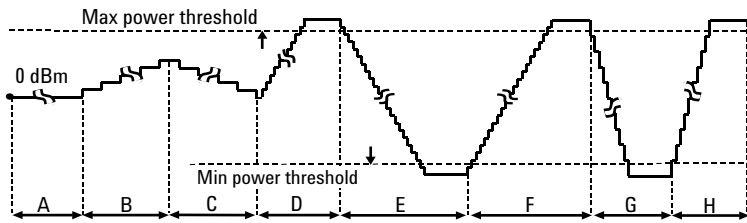

Figure 37. Pattern of power control steps defined in the inner loop power control (UL) in the 3GPP specifications [12]

2.4.5 Analysis of receiver's response to channel configuration changes

By demodulating dynamic channel configurations you can verify the receiver's response to changes in spreading factors, relative channel power, TFCI, etc. at frame boundaries.

This analysis requires a stimulus signal comprising a sequence of single frames, each of which consists of different channel configurations. Variability of all previously mentioned parameters on each frame is required.

2.4.6 Bit error rate (BER) versus block error rate (BLER)

BER is the figure of merit used in the standard for the receiver characteristics conformance tests (reference sensitivity level, ACS, etc.) [12].

BLER is used for the performance conformance tests (demodulation tests in multi-path conditions, etc.) [12].

BER counts the bit errors in the transport block after channel de-interleaving and decoding (see figure 38). BLER is also measured after channel de-interleaving and decoding by evaluating the cyclic redundancy check (CRC) on each transport block. Every rejected block counts as an error. Therefore, the main difference between BER and BLER is that BLER not only measures errors in the decoded block, but also in the CRC. BLER is generally a more useful measure of CDMA system performance than BER. However, BER tests remain in the 3GPP specifications [12] due to this measure being used to evaluate receiver RF performance during radio development and having been extensively used in system simulations of the reference measurement channels. There is no direct relationship between BER and BLER. Bit errors tend to come in clumps. This is how the system responds to single events happening at RF that would otherwise cause a block error.

Since W-CDMA employs robust coding algorithms, many errors can be corrected before bit errors are encountered. However, the "knee" of the BER curve is sharp, much sharper than the curves in systems that employ only moderate error correction. In W-CDMA, once the number of bit errors exceeds the capability of the error correction algorithms (e.g., convolutional encoding and interleaving), the BER climbs from a negligible value to one that is unrecoverable.

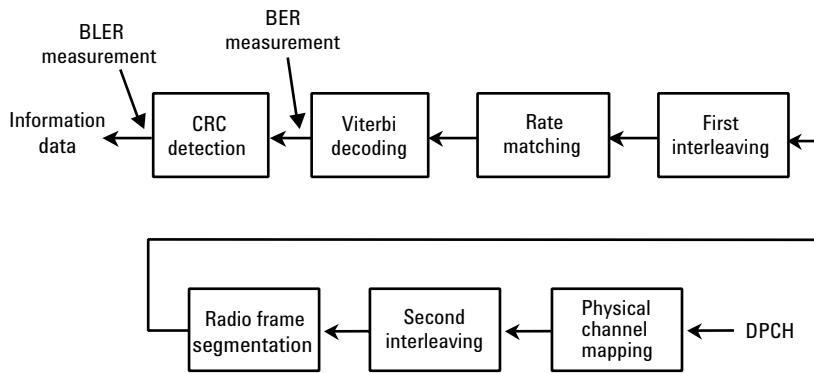

Figure 38. BER and BLER measurements in the DL

In order to make the BER and BLER conformance tests, the standard requires a fully-coded signal as a stimulus, comprising a CPICH, a P-CCPCH, a SCH, an orthogonal channel noise simulator (OCNS), and a DPCH.

The CPICH, P-CCPCH and SCH are used by the UE receiver for synchronization, as described in section 2.4.1.

The BER or BLER measurements must be performed on the DPCH. A DL reference measurement channel is specified as the DPCH for each test [12]. With this reference, the complete coding and structure for the DPCH is defined. All the receiver characteristics tests only require the 12.2 kbps reference measurement channel. Each of the performance tests, however, must be performed for several reference measurement channels [12]. Apart from the correct coding for the DPCH (as defined for the specific reference measurement channel), the stimulus must use a PN9 sequence as the information data for the DTCH (or the DCCH). The BER (or BLER) is calculated after the receiver decodes this DPCH data, as shown in figure 36. Appendix A shows the coding structure and parameters for the DL 12.2 kbps reference measurement channel [12].

The receiver and performance tests are intended to replicate real-life conditions. In real life, the DPCH will be transmitted at a low power compared to the total system power. However, this means that multiple channels would be required to perform the receiver tests, which would complicate the measurement. The OCNS solves this problem. The OCNS is a non-modulated orthogonal (it uses an OVSF code) channel. It represents other users in the system and therefore its power is specified at a higher level than the DPCH power.

The specification uses the reference measurement channels at selected data rates to ensure that a minimum level of performance (BER) is provided. The W-CDMA system's flexibility enables it to offer a wide variety of services from voice, to data, to video, to all these combined, all over a single connection (i.e., a service channel). Therefore, it is imperative to emulate the coding settings and channel combinations that will be employed during day-to-day operation. To this end, a signal generator should provide flexibility in input data rate, CRC size, coding (1/2 or 1/3 convolutional encoding, or turbo coding), rate matching, interleaving period, and TTI period.

On the other hand, the specifications have not been completely defined yet. In particular, the coding blocks and structure for the traffic channels may not be definite. For example, the parameters for the rate matching block may be different from the current specifications. Therefore, flexibility in the coding parameters of the stimulus signal is desirable to test different decoding structures. This is also useful to troubleshoot a problem evidenced by poor BER (or BLER) measurement results. For example, you can disable the interleaving in the reference measurement channel stimulus and the de-interleaving in the receiver to test the performance of the other blocks.

Summary

W-CDMA provides a wideband, dynamically allocatable code space that can provide high data rate communication to many users in a cell. As with other cellular CDMA technologies, W-CDMA provides the simplicity of cell site code planning (instead of cell site frequency planning) and can achieve this benefit without requiring GPS time synchronization.

The advanced features of W-CDMA, including its unique acquisition and handover processes, present many challenges in the development, performance verification, and production test of W-CDMA systems. This application note provided an overview of some of the key design and test issues for W-CDMA UE. It also introduced measurements that can help you verify and troubleshoot your design.

Appendix A: Reference measurement channel examples

The following reference measurement channel examples have been extracted from the 3GPP specifications [12].

UL reference measurement channel (12.2 kbps)

The parameters for the 12.2 kbps UL reference measurement channel are specified in table 3 and table 4. The channel coding is shown in figure 39.

Parameter	Level	Unit
Information bit rate	12.2	kbps
DPDCH	60	kbps
DPCCH	15	kbps
DPCCH slot format #i	0	-
DPCCH/DPDCH power ratio	-5.46	dB
TFCI	On	-
Repetition	23	%

Table 3. UL reference measurement channel physical parameters (12.2 kbps)

Parameters	DCCH	DTCH
Transport channel number	1	2
Transport block size	244	100
Transport block set size	244	100
Transmission time interval	20 ms	40 ms
Type of error protection	Convolution coding	Convolution coding
Coding rate	1/3	1/3
Rate matching attribute	256	256
Size of CRC	16	12

Table 4. UL reference measurement channel, transport channel parameters (12.2 kbps)

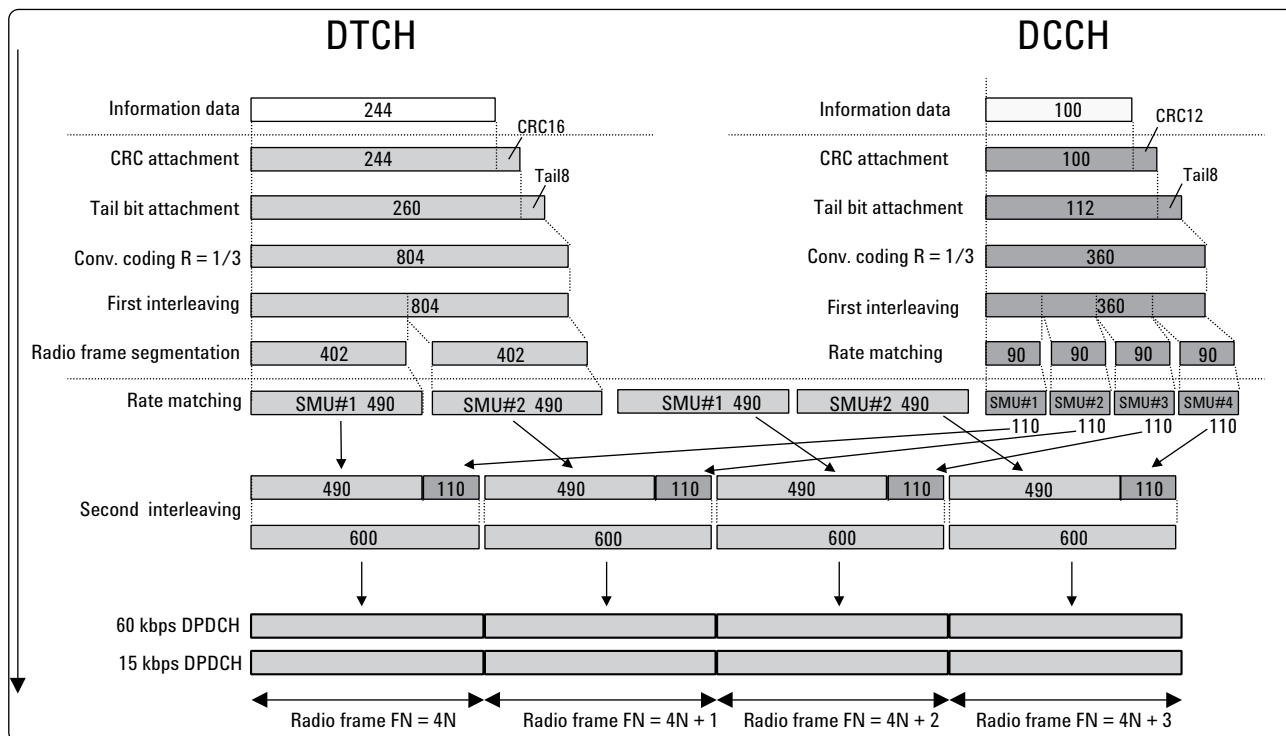

Figure 39. Channel coding of UL reference measurement channel (12.2 kbps)

DL reference measurement channel (12.2 kbps)

The parameters for the 12.2 kbps DL reference measurement channel are specified in table 5 and table 6. The channel coding is detailed in figure 40.

Parameter	Level	Unit
Information bit rate	12.2	kbps
DPCH	30	kspss
Slot format #i	11	-
TFCI	0n	
Power offsets PO1, PO2 and PO3	0	dB
Puncturing	14.7	%

Table 5. DL reference measurement channel (12.2 kbps)

Parameter	DCCH	DTCH
Transport channel number	1	2
Transport block size	244	100
Transport block set size	244	100
Transmission time interval	20 ms	40 ms
Type of error protection	Convolution coding	Convolution coding
Coding rate	1/3	1/3
Rate matching attribute	256	256
Size of CRC	16	12
Position of TrCH in radio frame	fixed	fixed

Table 6. DL reference measurement channel, transport channel parameters (12.2 kbps)

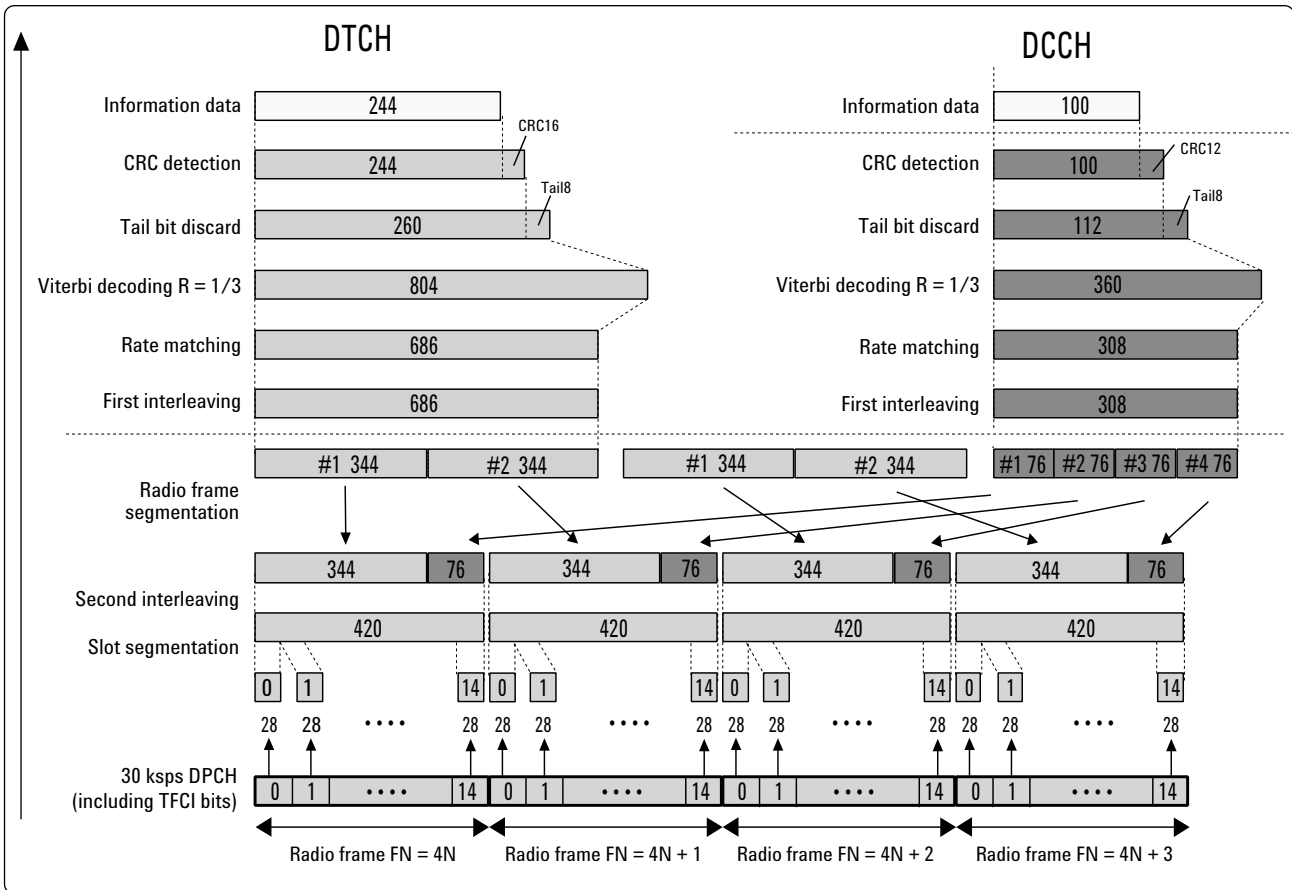

Figure 40. Channel coding of DL reference measurement channel (12.2 kbps)

Appendix B Agilent Solutions for W-CDMA UE design and test

This section provides a list of Agilent solutions that can you can use to design and test your UE subsystem and system.

Software design and simulation

You can use the Agilent Advanced Design System (ADS) to design and verify W-CDMA systems, circuits, and DSP designs. ADS is a versatile design tool that includes a wide array of RF, analog and DSP models, and simulation capability.

The 3GPP W-CDMA design library (E8875 A/AN) models the physical layer, including the data and control logical channels, frame segmenting and multiplexing forming the coded composite transport channel, and the multiplexing for the dedicated physical data and control channels.

ADS with the E8875 A/AN design library option helps you to evaluate your designs against key W-CDMA performance parameters such as ACLR, EVM, BER, and BLER early in the design cycle. Many transmitter and receiver tests outlined in the specifications [18] can be simulated, as shown in table 7.

UE transmitter tests		ADS E8875 A/AN
Peak-to-mean for selected channel configuration		X
CCDF for selected channel configuration		X
Transmitter tests [18]:	Transmit power	X
	Max output power	X
	Occupied bandwidth	X
	Out-of-band emission	X
	Spectrum emission mask	X
	Adjacent channel leakage	X
	Modulation accuracy	X
Peak code domain error	X	
UE receiver tests		ADS E8875 A/AN
Uncoded physical BER		X
Coded BER and receiver tests [18]:	Reference sensitivity level	X
	Receiver maximum level	X
	Adjacent channel selectivity	X
	Blocking sensitivity	X
	Intermodulation sensitivity	X

Table 7. W-CDMA test simulation capabilities of ADS with the E8875 A/AN design library option for UE design.

The E8875 A/AN design library also includes signal source configurations similar to those offered in the Agilent ESG-D/DP signal generator.

Signal generation

The Agilent ESG-D and ESG-DP series signal generators with Option 100 and the Agilent E4438C ESG Vector Signal Generator with Option 400 have the capability of simulating statistically-correct UL and DL signals for W-CDMA UE component, and subsystem transmitter testing. An easy-to-use interface allows you to:

- select from several predefined W-CDMA channel configurations
- use the table editor to fully configure a W-CDMA multi-channel signal per your requirements

In addition, Option H99 offers improved adjacent and alternate channel performance (ACLR), especially important to W-CDMA amplifier testing.

The Agilent ESG-D and ESG-DP series RF signal generators with Option 200 and the Agilent E4438C ESG Vector Signal Generator with Option 400 have the capability of simulating fully-coded UL and DL signals for UE component, subsystem and system receiver design. An easy-to-use interface allows you to select from predefined channel configurations, including all the reference measurement channels. Option 200 and 400 offer flexibility for user data input and coding parameter modification. The DL supports transport channels and the system frame number for BER. Option 400 also offers auto power balancing between the DPCH and 16 OCNS channels, one button setups for receiver characteristic testing, real time TPC input to control the UE transmit power (closed loop power control), and internally generated noise for easy control of carrier-to-noise ratio (C/N) and energy-per-chip-to-noise ratio (E_c/N_o). Option 200 and 400 do not support any higher level protocol.

Table 8 shows the W-CDMA stimulus capabilities for UE testing of the different ESG signal generator configurations.

		ESG Opt. 100	ESG Opt. 200 ¹	ESG E4438C Option 400 ²
Stimulus for component test		●	●	●
Stimulus for receiver tests:				
Verification of demodulation and de-spreading		●	●	●
Verification of control channel recovery and TFCI decoding		●	●	●
Verification of response to TPC commands		●	●	●
Analysis of receiver's response to dynamic changes		●	●	●
BER & receiver characteristics conformance tests [12]³	Reference sensitivity level		●	●
	Maximum input level			●
	Adjacent channel selectivity	As a modulated interferer		●
	Blocking characteristics	As a modulated interferer	●	●
	Spurious response		●	●
	Intermodulation characteristics	As a modulated interferer	●	●
Variable coding parameters (e.g. rate matching)			●	●
Auto power balancing between DPCH and 16 OCNS				●
Compressed mode capability				●

Table 8. W-CDMA stimulus capabilities of ESG signal generators for UE testing.

Battery simulation

Agilent 66319B/D, 66321B/D single and dual DC output high performance power supplies combined with the 14565A Device Characterization Software provide fast transient output response. They are designed for testing digital wireless appliances and provide the following functions:

- replace the main battery and power adapter
- emulate internal battery resistance
- fast output response emulates battery voltage response
- low voltage drop in response to pulsed current demands
- accurately measure battery current drains (DC average, leakage, standby mode, and talk mode)
- dual DC output models for testing and calibrating charger circuitry (source/sink capability)
- Graphical user interface software for easy power supply control and measurement setup (no programming required)

1. Two-box solution (two ESG signal generators required).
2. Option 400 contains both Option 100 and 200 capability. One-button receiver characteristics conformance tests. AWGN included in Option 400 sets C/N ratio.
3. Option 400 conforms to the June 2001 version of the specifications (3G TS 34.121 (V3.5.0)), while Option 200 and 100 conform to the December 2000 version of the specifications (3G TS 34.121 (V3.3.0)).

Power meter and sensor

The Agilent EPM-P series power meters and E9320 peak and average power sensors provide peak, average and peak-to-average ratio power measurements on W-CDMA signals. Extensive triggering features are available for making time-gated measurements. Fast test times, with a measurement speed of up to 1,000 corrected readings per second, over the GPIB, help increase throughput to meet time-to-market and time-to-volume goals. The E9320 peak and average power sensors have a maximum video bandwidth of 5 MHz, ideal for W-CDMA power measurements.

EPM-P analyzer software is provided with the EPM-P series power meters. This is a PC-based tool for pulse and statistical analysis on TDMA and CDMA modulation formats. For statistical analysis of the power distribution, the EPM-P analyzer software provides the capability to determine the probability density function (PDF), cumulative density function (CDF), and CCDF on W-CDMA signals.

Recommended power meters and sensors for 3GPP W-CDMA users equipment peak, average and time-gated power measurements are:

- EPM-P series power meter E4416A, single channel,
- EPM-P series power meter E4417A, dual channel, and the
- E9323A peak and average power sensor, 50 MHz to 6 GHz, 5 MHz video bandwidth, -60 to +20 dBm.

All 8480 and E-series power sensors are compatible with the EPM-P series power meters.

For average power measurements only, the lower cost EPM series power meters and other E-series power sensors recommended are:

- EPM series power meter E4418B, single channel,
- EPM series power meter E4419B, dual channel,
- E9301A power sensor, 10 MHz to 6 GHz, -60 to +20 dBm, and the
- E9301H power sensor, 10 MHz to 6 GHz, -50 to +30 dBm.

Other power sensors in the 8480 series are compatible with the EPM series power meters.

Signal analysis

Table 8 provides a list of Agilent signal analyzers and their W-CDMA UE transmitter measurement capabilities (as of November 2001).

W-CDMA (3GPP)		Agilent signal analyzers					One box test set
Measurements		E4406A VSA transmitter tester ¹	89400 series vector signal analyzers ³	89600 series vector signal analyzers ²	E4440A PSA series spectrum analyzers ¹	ESA-E series spectrum analyzers ¹	8960 wireless communications test set ¹
General-purpose measurements							
Channel power		●	● ⁴	● ⁴	●	●	●
CCDF		●	●	●	●	●	
Modulation quality	QPSK EVM	●	●	●	●	●	
	Composite EVM	●		●	●		●
	Code domain power	●		●	●		
	Peak code domain error	●		●	●		
	Symbol EVM	●		●	●		
	Symbol power versus time	●		●	●		
	Composite chip power versus time	●		●	●		
	Demodulated bits	●		●	●		
Transmitter conformance tests [12]							
Maximum output power (5.2)		●	● ⁴	● ⁴	●	●	●
Frequency stability (5.3)		● ⁶		● ⁶	● ⁶		●
Output dynamics in the uplink (5.4)		● ⁴	● ⁴	● ⁴	● ⁴	● ⁴	● ⁴
Transmit OFF power (5.5.1)		● ⁴	● ^{4,5}	● ^{4,5}	● ⁴	● ⁴	● ⁴
Occupied bandwidth (5.8)		●	● ⁴	● ⁴	●	●	
Spectrum emission mask (5.9)		●	● ⁴	● ⁴	●	●	
ACLR (5.10)		●			●	●	●
Spurious emissions (5.11)					● ⁴	● ⁴	
Transmit intermodulation (5.12)					● ⁴	● ⁴	
Modulation accuracy (5.13.1)		●		●	●		●
Peak code domain error (5.13.2)		●		●	●		

Table 8. Agilent signal analysis tools for W-CDMA

1. Measurements pre-configured for W-CDMA.
2. Some measurements pre-configured for W-CDMA. Parameters for other measurements must be set up manually, as indicated (4).
3. Measurements are not pre-configured for W-CDMA. Measurement parameters must be set up manually, as indicated (4).
4. Measurement parameters must be set up manually.
5. Trace math must be used to apply the specified root-raised cosine filter. Otherwise, the measurement is performed using a rectangular filter. In this case, the error is smaller than 0.1 dB.
6. Frequency stability measurement is performed over more than one timeslot.

Wireless communication test set

The Agilent E1963A W-CDMA mobile test application for the multi-format Agilent 8960 Series 10 (E5515C) wireless communications test set is the first to offer designers and manufacturers of 3G mobile phones all Third Generation Partnership Project (3GPP) formats – GSM, GPRS, and W-CDMA – in a single instrument. It is the only test set on the market capable of testing all radio formats of the first wave of 3GPP mobile devices.

Speed product design and verification by putting a W-CDMA system simulator and fast parametric test set on your desk. As prototypes move into production, the test solution's fast measurements, accuracy, flexibility, and ease of programming will help you quickly reach high-volume production goals.

E1963A provides the following test capabilities:

- thermal power
- channel power
- ACLR
- modulation quality (composite EVM and related error metrics: phase error, I/Q offset, etc).
- frequency error
- loopback BER

Instruments used for measurement examples

The measurement examples and screen images in this application note were obtained using the following instruments:

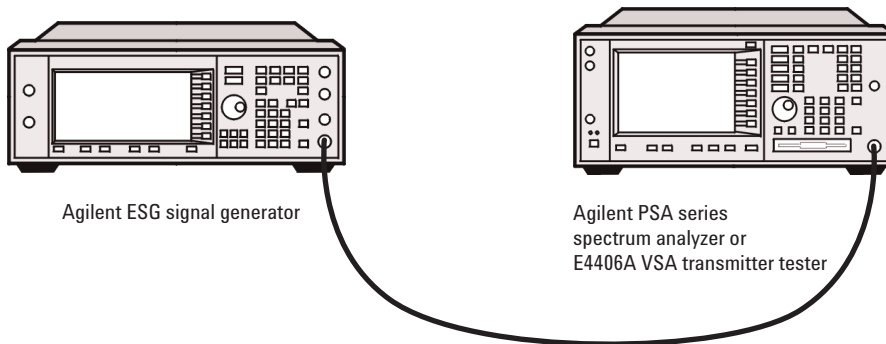

Acronym glossary

2G	Second Generation	IS-2000	EIA/TIA interim standard 2000 (see cdma 2000)
3G	Third Generation	IS-95	Interim standard for U.S. Code Division Multiple Access
3GPP	Third-Generation Partnership Project	LO	Local Oscillator
ACIR	Adjacent Channel Interference Ratio	MAC	Medium Access Control
ACL	Adjacent Channel Leakage	OCNS	Orthogonal Channel Noise Simulator
ACLR	Adjacent Channel Leakage Power Ratio	OCQPSK	Orthogonal Complex Quadrature Phase Shift Keying
ACPR	Adjacent Channel Power Ratio	OVSF	Orthogonal Variable Spreading Factor
ACS	Adjacent Channel Selectivity	PA	Power Amplifier
AICH	Acquisition Indication Channel	PAE	Power-Added Efficiency
ARIB	Association of Radio Industries and Businesses (Japan)	PAR	Peak-to-Average Power Ratio
BCH	Broadcast Channel	PCCH	Paging Control Channel
BCCH	Broadcast Control Channel	P-CCPCH	Primary Common Control Physical Channel
BER	Bit Error Rate	PCPCH	Physical Common Packet Channel
BLER	Block Error Rate	PDC	Pacific Digital Cellular System
BPSK	Binary Phase Shift Keying	PDF	Probability Density Function
BTS	Base Transceiver Station	PDSCH	Physical Downlink Shared Channel
CCCH	Common Control Channel	PICH	Paging Indication Channel
CCDF	Complementary Cumulative Distribution Function	PN	Pseudo-Noise
CCTrCH	Coded Composite Transport Channel	PRACH	Physical Random Access Channel
CDF	Cumulative Density Function	PSC	Primary Synchronization Code
CDMA	Code Division Multiple Access	P-SCH	Primary Synchronization Channel
cdmaOne	Name identifying the EIA/TIA standard (commonly referred to as IS-95) for 2G	PSK	Phase Shift Keying
cdma2000	Name identifying the EIA/TIA standard (IS-2000) for 3G	QAM	Quadrature Amplitude Modulation
C/N	Carrier-to-Noise Ratio	QPSK	Quadrature Phase Shift Keying
CPCH	Common Packet Channel	RACH	Random Access Channel
CPICH	Common Pilot Channel	R&D	Research and Development
CRC	Cyclic Redundancy Check	RF	Radio Frequency
CW	Continuous Wave (unmodulated signal)	RLC	Radio Link Control
DCH	Dedicated Channel	RMS	Root Mean Square
DCCH	Dedicated Control Channel	RRC	Root Raised Cosine
DL	Downlink	RRS	Radio Resource Control
DPCCCH	Dedicated Physical Control Channel	S-CCPCH	Secondary Common Control Physical Channel
DPDCH	Dedicated Physical Data Channel	SCH	Synchronization Channel
DQPSK	Differential Quadrature Phase Shift Keying	SF	Spreading Factor
DSP	Digital Signal Processing	SFN	System Frame Number
DTCH	Dedicated Traffic Channel	SIR	Signal to Interference Ratio
E_b/N_0	Energy-per-Bit-to-Noise Ratio	SSC	Secondary Synchronization Code
E_c/N_0	Energy-per-Chip-to-Noise Ratio	S-SCH	Secondary Synchronization Channel
ETSI	European Telecommunications Standard Institute	TDD	Time Division Duplex
EVM	Error Vector Magnitude	TDMA	Time Division Multiple Access
FACH	Forward Access Channel	TFCI	Transport Format Control Indicator
FBI	Feedback Information	TIA	Telecommunications Industries Association (U.S.)
FDD	Frequency Division Duplex	TPC	Transmit Power Control
GMSK	Gaussian Minimum Shift Keying	TTA	Telecommunications Technology Association (Korea)
GPS	Global Positioning System	TTC	Telecommunication Technology Committee (Japan)
GSM	Global System for Mobile Communications	UE	User Equipment
HPSK	Hybrid Phase Shift Keying	UL	Uplink
IF	Intermediate Frequency	UMTS	Universal Mobile Telephone System (Europe)
IMT-2000	International Mobile Telecommunications-2000 (Collective name for 3G technologies approved by the ITU)	W-CDMA	Wideband-Code Division Multiple Access (3G system)
I/Q	In-phase/Quadrature		

For more information regarding these acronyms and other wireless industry terms, please consult our wireless dictionary at: www.agilent.com/find/wireless

References

- [1] "3G Market Overview and Technology Basics for cdma2000 and UTRA (ETSI W-CDMA)." Agilent Technologies Wireless R&D Symposium, 1999.
- [2] 3rd Generation Partnership Project. Technical Specification Group Radio Access Network. Multiplexing and Channel Coding (FDD). Release 99. 3G TS 25.212 (V3.6.0).
- [3] 3rd Generation Partnership Project. Technical Specification Group Radio Access Network. Medium Access Control Protocol Specification. Release 99. 3G TS 25.321.
- [4] 3rd Generation Partnership Project. Technical Specification Group Radio Access Network. Radio Link Control Protocol Specification. Release 99. 3G TS 25.322.
- [5] 3rd Generation Partnership Project. Technical Specification Group Radio Access Network. Radio Resource Control Protocol Specification. Release 99. 3G TS 25.331.
- [6] 3rd Generation Partnership Project. Technical Specification Group Radio Access Network. Radio Interface Protocol Architecture. Release 99. 3G TS 25.301.
- [7] 3rd Generation Partnership Project. Technical Specification Group Radio Access Network. Physical Layer: Physical Channels and Mapping of Transport Channels onto Physical Channels (FDD). Release 99. 3G TS 25.211 (V3.7.0).
- [8] *HPSK Spreading for 3G*, Application Note 1335, literature number 5968-8438E.
- [9] 3rd Generation Partnership Project. Technical Specification Group Radio Access Network. Physical Layer: Spreading and Modulation (FDD). Release 99. 3G TS 25.213. (V3.6.0).
- [10] 3rd Generation Partnership Project. Technical Specification Group Radio Access Network. Physical Layer: Channel Coding and Multiplexing Examples. Release 99. 3G TS 25.944. (V3.5.0).
- [11] R.N. Braithwaite, "Nonlinear Amplification of CDMA Waveforms: An Analysis of Power Amplifier Gain Errors and Spectral Regrowth." Proceedings of the 48th IEEE Vehicular Technology Conference (1998): 2160-2166.
- [12] 3rd Generation Partnership Project. Technical Specification Group Terminal, Terminal Conformance Specification. Radio Transmission and Reception (FDD). Release 99. 3G TS 34.121. (V3.5.0).
- [13] *Fundamentals of RF and Microwave Power Measurements*, Application Note 64-1B, literature number 5965-6630E.
- [14] *Wide-Range Sensor Gauges Power of Complex Signals* (written by Ron Hogan and originally printed in *Microwaves & RF*, September 1999), literature number 5968-8750E.
- [15] *Characterizing Digitally Modulated Signals with CCDF Curves*, Application Note, literature number 5968-6875E.
- [16] *Testing and Troubleshooting Digital RF Communications Transmitter Designs*, Application Note 1313, literature number 5968-3578E.
- [17] *Testing and Troubleshooting Digital RF Communications Receiver Designs*, Application Note 1314, literature number 5968-3579E.
- [18] 3rd Generation Partnership Project. Technical Specification Group Radio Access Network. UE Radio Transmission and Reception (FDD). Release 99. 3G TS 25.101 (V3.6.0).

Related literature

3GPP W-CDMA Design Library, literature number 5980-0953E.

89400 Series Vector Signal Analyzers, literature number 5965-8554E.

89600 Series Wide-Bandwidth Vector Signal Analyzers, literature number 5980-0723E.

E4406A Vector Signal Analyzer Brochure, literature number 5968-7618E.

PSA Series Performance Spectrum Analyzers, literature number 5980-1283E.

ESA-E Series Spectrum Analyzers, literature number 5968-3278E.

EPM Series Power Meters, literature number 5965-6380E.

EPM-P Series Single- and Dual-Channel Power Meters/E9320 Family of Peak and Average Power Sensors, literature number 5980-1471E.

ESG Series RF Digital and Analog Signal Generators, literature number 5968-4313E.

E4438C ESG Vector Signal Generator, literature number 5988-3935EN.

8960 Series 10 Wireless Communications Test Set, literature number 5968-7876E.

Mobile Communications dc Source Product Overview, literature number 5980-0875E.

Acknowledgements

Agilent Technologies would like to acknowledge Darryl Schick of 3G Wireless Training, Division of Linear Lightwave, Inc., for his technical contributions in developing this application note.

Agilent Technologies' Test and Measurement Support, Services, and Assistance

Agilent Technologies aims to maximize the value you receive, while minimizing your risk and problems. We strive to ensure that you get the test and measurement capabilities you paid for and obtain the support you need. Our extensive support resources and services can help you choose the right Agilent products for your applications and apply them successfully. Every instrument and system we sell has a global warranty. Support is available for at least five years beyond the production life of the product. Two concepts underlie Agilent's overall support policy: "Our Promise" and "Your Advantage."

Our Promise

Our Promise means your Agilent test and measurement equipment will meet its advertised performance and functionality. When you are choosing new equipment, we will help you with product information, including realistic performance specifications and practical recommendations from experienced test engineers. When you use Agilent equipment, we can verify that it works properly, help with product operation, and provide basic measurement assistance for the use of specified capabilities, at no extra cost upon request. Many self-help tools are available.

Your Advantage

Your Advantage means that Agilent offers a wide range of additional expert test and measurement services, which you can purchase according to your unique technical and business needs. Solve problems efficiently and gain a competitive edge by contracting with us for calibration, extra-cost upgrades, out-of-warranty repairs, and on-site education and training, as well as design, system integration, project management, and other professional engineering services. Experienced Agilent engineers and technicians worldwide can help you maximize your productivity, optimize the return on investment of your Agilent instruments and systems, and obtain dependable measurement accuracy for the life of those products.

By internet, phone, or fax, get assistance with all your test and measurement needs.

Online assistance:

www.agilent.com/find/assist

Phone or Fax

United States: Japan:
(tel) 1 800 452 4844 (tel) (81) 426 56 7832
(fax) (81) 426 56 7840

Canada: Korea:
(tel) 1 877 894 4414 (tel) (82 2) 2004 5004
(fax) (905) 282 6495 (fax) (82 2) 2004 5115

China: Taiwan:
(tel) 800 810 0189 (tel) 080 004 7866
(fax) 1 0800 650 0121 (fax) (886 2) 2545 6723

Europe: Other Asia Pacific Countries:
(tel) (31 20) 547 2323 (tel) (65) 375 8100
(fax) (31 20) 547 2390 (fax) (65) 836 0252

Latin America: Email: tm_asia@agilent.com
(tel) (305) 269 7500
(fax) (305) 269 7599

Product specifications and descriptions in this document subject to change without notice.
© Agilent Technologies, Inc. 2001
Printed in U.S.A., December 10, 2001
5980-1238E

